

YEAR 2 PROJECT REPORT

MONITORING AND MAPPING THE AREA, EXTENT AND SHIFTING GEOGRAPHIES OF INDUSTRIAL FORESTS IN THE TROPICS

David L. Skole

*Michigan State University
Principal Investigator*

Larry Leefers

*Michigan State University
Co-Investigator*

Pascal Nzokou

*Michigan State University
Co-Investigator*

Michigan, December 01, 2015

TABLE OF CONTENT

LIST OF TABLE

LIST OF FIGURE

I. Industrial Forest Development in the Selected Countries and Determination of the Pilot Study Sites	1
1.1 Literature Review on IF Development in the Selected Countries (Task 1)	1
1.2 Industrial Forest Policy Assessment in the Targeted Countries (Task 2)	13
1.3 Determination of the Pilot Study Sites	17
II. Silvicultural Practice Assessments	28
III. Methods Development for Detecting, Mapping, & Monitoring Industrial Forests For Landsat Data (Task 4)	33
VI. References	65

LIST OF TABLES

Figure 1.	Commercial plantation area by species in India in 2000	2
Figure 2.	Total area of tree plantations in India from 2005-2010	2
Figure 3.	Newly established plantation area total under different programs by state, 2000-2010	3
Figure 4.	The commercial plantation area in Indonesia in 2005	4
Figure 5.	The industrial timber plantation area in Indonesia, 2001, 2009, and 2012	5
Figure 6.	The distribution of pulp and sawnwood plantations in Indonesia	5
Figure 7.	Thailand commercial plantation area in 2005	7
Figure 8.	Thailand rubber distribution in different regions	7
Figure 9.	The distribution of <i>Eucalyptus</i> plantations by region in Thailand in 1997	8
Figure 10.	The commercial plantation by species in Malaysia in 2005	9
Figure 11.	The distribution of plantations (rubber in 2005 & other plantations in 2009) in Malaysia	9
Figure 12.	Industrial plantation development in Sarawak, 1997-2012	10
Figure 13.	Plantation area by species in 2000 in Viet Nam	11
Figure 14.	Total plantation area by type (production vs. protection) from 2002 to 2012 in Viet Nam	12
Figure 15.	The development of forest plantations (10 ³ ha) by region, 2005 to 2009, in Viet Nam	12
Figure 16.	The distribution of Viet Nam's rubber plantations	13
Figure 17.	Country-specific context and drivers of industrial forest (IF) plantation change	17
Figure 18.	The annual expansion rate under 20-point program in India from 2006-2010	18
Figure 19.	Map of India showing the Andhra Pradesh (red) and Madhya Pradesh (purple).	18

Figure 20.	Map of Indonesia showing the selected pilot study sites: East Kalimantan (light yellow); West Kalimantan (purple) or Papua (light blue)	21
Figure 21.	Map of Thailand presenting the selected region (North East in pink color) for the pilot study sites	23
Figure 22.	Map of Malaysia showing the selected pilot study sites (Sarawak & Sabah)	26
Figure 23.	Map of Viet Nam showing the pilot study sites (North East and Central Highlands)	26
Figure 24.	The general flowchart for developing the Landsat data-based IF detection methods	34
Figure 25.	The flowchart of vegetation indices/VI-based IF detection method development	36
Figure 26.	The MSAVI _{af} images stacked for Sabah from 2000 to 2014	37
Figure 27.	The VI value change detection at $\pm 15\%$ for Sabah and Sarawak, 2012-2014	37
Figure 28.	The cycles of clearing and regrowth of vegetation cover (rotation) based on the changes of MSAVI _{af} values in Sarawak from 2000 to 2014	38
Figure 29.	Possibly shorter & longer rotation plantations based on MSAVI _{af} from 2000 to 2014 in Sarawak	39
Figure 30.	The possibly faster growing and slower growing plantations based on the growth rate of MSAVI _{af} values in Sarawak from 2000 to 2014	40
Figure 31.	Possibly faster-growing, shorter-rotation and slower-growing, longer-rotation plantations in Sarawak from 2000 to 2014	41
Figure 32.	The Mean index in GLCM is calculated for a NDVI _{af} image in 2014	42
Figure 33.	The values of GLCM_MEA, HOM, & DIS of different Land Uses/Land Covers in the NDVI _{af} product, band 4, & band 5 grey level images in Sabah, 2000-2014	43
Figure 34.	The texture-based models for the VI datasets to detect the focused IF systems	44
Figure 35.	Detecting the targeted IF systems based on textural analysis in Sabah, 2012	44
Figure 36.	Spectral analysis/transformation results (PCA, ICA, & TCA) for Sabah and Sarawak in 2000	46

Figure 37.	The Principal and Independent Components values for acacias, natural forests, oil palms, rubbers, and other industrial forests of layers 1, 2, & 3 in Sabah, 2000-2014	47
Figure 38.	The Tasseled Cap values for acacias, natural forests, oil palms, rubbers, and other industrial forests of layers 1, 2, 3, 4, 5, & 6 in Sabah, 2000-2014	48
Figure 39.	The mean values of band 4 and band 5 for the different land use/land cover areas of interest in Sabah, 2000-2014	49
Figure 40.	The spectra-based models for the VI datasets to detect the focused IF systems	49
Figure 41.	Detecting the IFs based on spectral analysis in Sabah, 2014	50
Figure 42.	Visual interpretation-based IF map in Sabah, 2000	50
Figure 43.	General IF detection model based on the combinations of different datasets	51
Figure 44.	The different VIs-based IF detection maps in Sabah, 2014	52
Figure 45.	The flowchart of the <i>fC</i> -based IF detection method development	54
Figure 46.	The endmember values of closed forests and bare soils/lands for MSAVI _{af} products in Sarawak and Sabah, 2000-2014	55
Figure 47.	The forest/vegetation fractional covers (<i>fC</i>) produced from the MSAVI _{af} products in 2014 for Sarawak and Sabah	56
Figure 48.	The <i>fC</i> changes detection for 2012-2014 in Sarawak and Sabah	56
Figure 49.	The possibly shorter & longer rotation IFs based on <i>fC</i> datasets in Sabah and Sarawak	57
Figure 50.	The possibly faster growing and slower growing industrial forests based on <i>fC</i> datasets in Sabah and Sarawak	58
Figure 51.	The possibly shorter-rotation faster-growing and longer-rotation slower-growing industrial forests based on <i>fC</i> datasets in Sabah and Sarawak	58
Figure 52.	The band 4 values in the same vegetation cover in Sarawak (a), and the band 4 value for different vegetation types from 2000 to 2014 in Sabah	59
Figure 53.	The MSAVI _{af} -based LAI for different vegetation cover types in Sabah and Sarawak, 2000-2014	60

Figure 54.	The textural analysis-based land use/land cover map for the <i>fC</i> dataset in Sabah and Sarawak in 2000	61
Figure 55.	The spectral analysis-based land use/land cover map based the <i>fC</i> dataset in Sabah and Sarawak, 2003	62
Figure 56.	The combinations of different datasets to detect and map IFs in Sabah & Sarawak	63
Figure 57.	The <i>fC</i> dataset-based IF detection and map for Sabah and Sarawak in 2009	64

LIST OF TABLES

Table 1.	Research collaborators on context and drivers of plantation change, by country	16
Table 2.	The summary of India's new plantation area and rate by state from 2000 to 2010	19
Table 3.	The summary of Indonesia's new plantation area and rate by province from 2009 to 2012	22
Table 4.	The summary of Thailand's new plantation area and rate by species and regions	24
Table 5.	A summary of plantation areas and the rate of its change by state in Malaysia	25
Table 6.	A summary of plantation areas and the rate of its change by regions in Viet Nam from 2005 to 2012	27
Table 7.	The summary of IF silvicultural practices for the selected species in India	28
Table 8.	The summary of IF silvicultural practices for the selected species in Indonesia	29
Table 9.	The summary of IF silvicultural practices for the selected species in Malaysia	30
Table 10.	The summary of IF silvicultural practices for the selected species in Thailand	31
Table 11.	The summary of IF silvicultural practices for the selected species in Viet Nam	32

INTRODUCTION

Tropical forest conversion is a major driver of climate change, and contributes as much as 25% of global carbon dioxide emissions. The main agent of deforestation and degradation over the last twenty years has been the conversion of closed canopy tropical forests to agriculture. Logging and forest management have not been as important as outright clearing of forests for agriculture, even while some early reports have painted a dire picture of a looming threat from commercial logging in the Amazon and some other areas (Nepstad et al. 1999).

These threats have not turned out to be as quantitatively significant as once feared and seem isolated to key hot spots but not widespread; Matricardi et al. (Matricardi et al. 2013, Matricardi et al. 2010, Matricardi et al. 2007, Matricardi et al. 2005) intensively studied commercial forest logging in the whole Amazon at three dates and found an increasing rate of land degradation from logging, but it was not quantitatively as important as pasture conversion. Further, the reported strong link between logging, understory fire, and forest conversion does not appear to hold true except in some key local hot spots.

From these limited studies one might conclude that commercial forestry and forest extraction continue to be important but second-order disturbance compared to agricultural conversion, except in some well known places including Malaysia and Indonesia. However, it is the premise of this project that the issue is far from being resolved. First, the vast majority of research has been focused on selective logging and degradation in intact natural forests, usually considered as a form of one-off harvest or culling rather than a form of intensive forest management. This is a very different phenomenon than the *establishment* of industrial forests (IF) in natural forestland as well as on non-forest land, which are associated with the dynamics of management and rotation. Second, the studies done to-date are geographically limited and thus may represent special cases not reflective of a general or widespread LCLUC phenomenon.

As such we need to have a much better understanding of the extent and dynamics of industrial forestry and commercial forest logging – empirically and from the perspective of understanding drivers.

The team that is developing this project has been trying to address what we believe are the key open questions of LCLUC in tropical forest systems, both from a monitoring perspective and a “drivers” perspective. There has been considerable work done within the NASA LCLUC program and other ecosystem and land science programs in NASA and other agencies on closed canopy tropical forest LCLUC dynamics. Now, the important next stage for research on drivers and dynamics is, we believe, in three new types of LCLUC and landscapes: 1) industrial forests (as in this solicitation), 2) open forests, woodlands and savannas, and 3) systems of trees outside of forests, principally in agricultural landscapes. Skole et al. (2013) address the details of this research agenda. *It is the aim of this project to focus on the first aforementioned area of interest. This requires new and innovative analysis and methods, first to develop new methods for detecting industrial forests in time series of remote sensing data, and second to analyze the spatial patterns to understand underlying LCLUC processes and drivers. Hence this project is largely basic LCLUC research but will do both development work and apply the remote sensing methods to create some early prototype monitoring datasets and maps.*

NEW DRIVING FORCES OF LCLUC: INDUSTRIAL FORESTS

Arguably, two important megatrends are having a transformational impact on global LCLUC (Skole and Simpson 2010):

- 1) A global investment and policy shift toward biomass-based fuels and biomass feed stocks, driven by concerns over climate change, as well as declining supplies of fossil fuels for energy and materials,
- 2) Growing economic importance of a rapidly rising demand and associated emerging markets for natural resources, particularly in Asia (cf. China and India).

As a result there are large and increasing investments being made in land resource development by all types of investors, from smallholders to industry. More precisely, these megatrends are forcing large scale shifts in land use and land cover; for instance natural forests and food-based agriculture systems are being converted to industrial tree systems (plantations). Preliminary evidence suggests that the area of industrial forest land use is increasing globally. More interesting, there appears to be significant geographic shifts in the location of new industrial tree systems, as industrial wood production that has historically been located in the temperate zone is now moving to tropical production centers and source regions.

This project is focused on documenting and understanding this new LCLUC trend and phenomenon in the tropical forest regions of the world. There is very little data on the rate, location, and scale patterns of industrial forests as an LCLUC system. Thus this project will contribute to an international need for this kind of information. FAO's major effort to establish a global plantation database needs to be commended but the fact is their data are often very unreliable, due to a survey approach, and their current plantation database is not slated to be updated any time soon.

KEY QUESTIONS POSED IN THE PROJECT

We aim to improve the knowledge base on the extent, characteristics and drivers of industrial forests as a new agent of LCLUC. The project will use remote sensing data from Landsat 8, and develop new methods to detect and quantify industrial forest LCLUC patterns and dynamics. These methods will be prototyped in selected and important geographic regions with the goal of producing an operational monitoring method for this LCLUC phenomenon. Several specific research questions are framed to guide research using Landsat 8 data on patterns to

quantitative address key questions related to processes and drivers.

The questions posed in this project are as follows:

- In selected key tropical forest geographic regions is there observational evidence that new industrial forests are increasing in area; if so where is this occurring; what types of natural or managed ecosystem are they replacing? Are these systems encroaching on natural forests or are they being used to re-establish forest biomass on non-forest or degraded land?
- Can we document from other evidence and ancillary data that there are new large scale shifts in the geographic locations of source areas for industrial wood production?
- What are the geometric and scale properties of industrial forests? Preliminary reports suggest that the sizes of industrial forests in the tropical forest zones are increasing; is this borne out by the observational evidence? Is there observational evidence to document short rotation (cf. pulp and paper) vs. long rotation (e.g. timber) industrial forests?
- Can we deploy a method using Landsat 8 with prior Landsat datasets that could operationally monitor, and quantitatively report, on the area and rate and scale of industrial forests on a regular basis?

PROGRESS REPORTING

This project report has 4 sections that describe our work in Year 2, including

- (1) Industrial forest development in the selected countries and determination of the pilot study sites, which is focused on Task 1 (*Stratification of the Asian Pacific Region for IF Source Areas*), Task 2 (*Analytical Assessment of Forest Investment and Policy Targets for Production Areas*), and Task 3 (*Development of Pilot Projects for Methods Development*) in the Project Proposal;
- (2) Industrial forest silvicultural practices assessment in the selected countries, which is related to Task 2;
- (3) Methods development for Landsat data, which is related to Task 4 (*Methods Development for Landsat Data*); and
- (4) References.

The progress to date in each Task area and selected preliminary findings are presented. Tasks 5 – 9 are major efforts for the next year.

I. Stratification of the Asian Pacific Region for IF Source Areas: Forest Development in the Selected Countries and Determination of the Pilot Study Sites

1.1. Literature Review on IF Development in the Selected Countries (Task 1)

INDIA

India is one of the biggest players in planting forests in the world. Since the 1980's, India has promoted the investment for plantations under different programs such as agroforestry and social forestry ([Ministry of Environment and Forests of India, 2007](#)). The [Food and Agriculture Organization \(FAO, 2000\)](#) reported India had a total of 32.5 Mha of plantations, which accounted for approximately 17% of the globe's total plantation area and was the second largest in the world only after China according to the [International Tropical Timber Organization \(ITTO, 2009\)](#). Of that, 45% of plantation species are fast growing species (mostly *Eucalyptus* and *Acacia* spp.) and [teak](#) (8%). [ITTO \(2009\)](#) also estimated the commercial plantation (or industrial forest/IF) area total in 2000 about 8.2 Mha including [teak](#) (2.6 Mha), [eucalypts](#) (2 Mha), [acacias](#) (1.6 Mha), [pines](#) (0.6 Mha), [rubber](#) (0.6 Mha), and others (0.8 Mha) ([Figure 1](#)). The [India Council of Forestry Research and Education \(ICFRE, 2010\)](#) indicated that the increase of India's total forest area recently resulted from various plantation and afforestation schemes. Most significantly, the Twenty Points Program (TPP) for Afforestation (since 1970 and restructured in 2006) includes plantation areas under the State Forest Departments (FD), and the National Afforestation Program (NAP) that have expanded at the rate of 1-2 Mha annually ([Figures 2 & 3](#)). The area and rate of plantation establishments were different in different states. The biggest area and highest rates of tree plantation establishments were found in some key states such as Andhra Pradesh, Madhya Pradesh, Gujarat, and Maharashtra ([ICFRE, 2010 & 2011](#)).

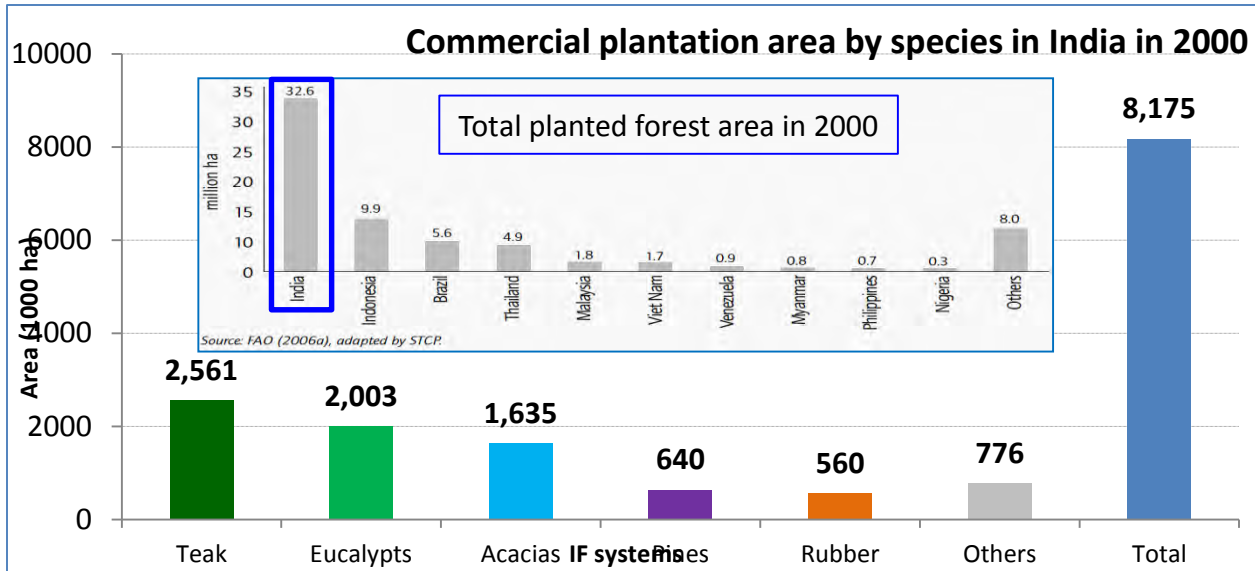

Figure 1. Commercial plantation area by species in India in 2000 (source: ITTO, 2009).

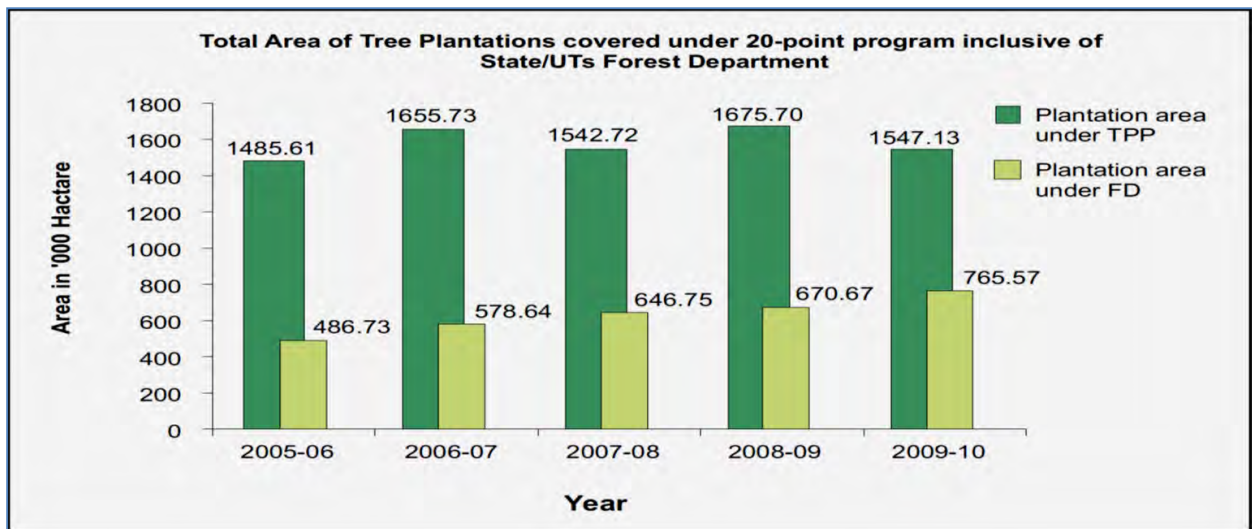

Figure 2. Total area of tree plantations in India from 2005-2010 (source: ICFRE, 2010).

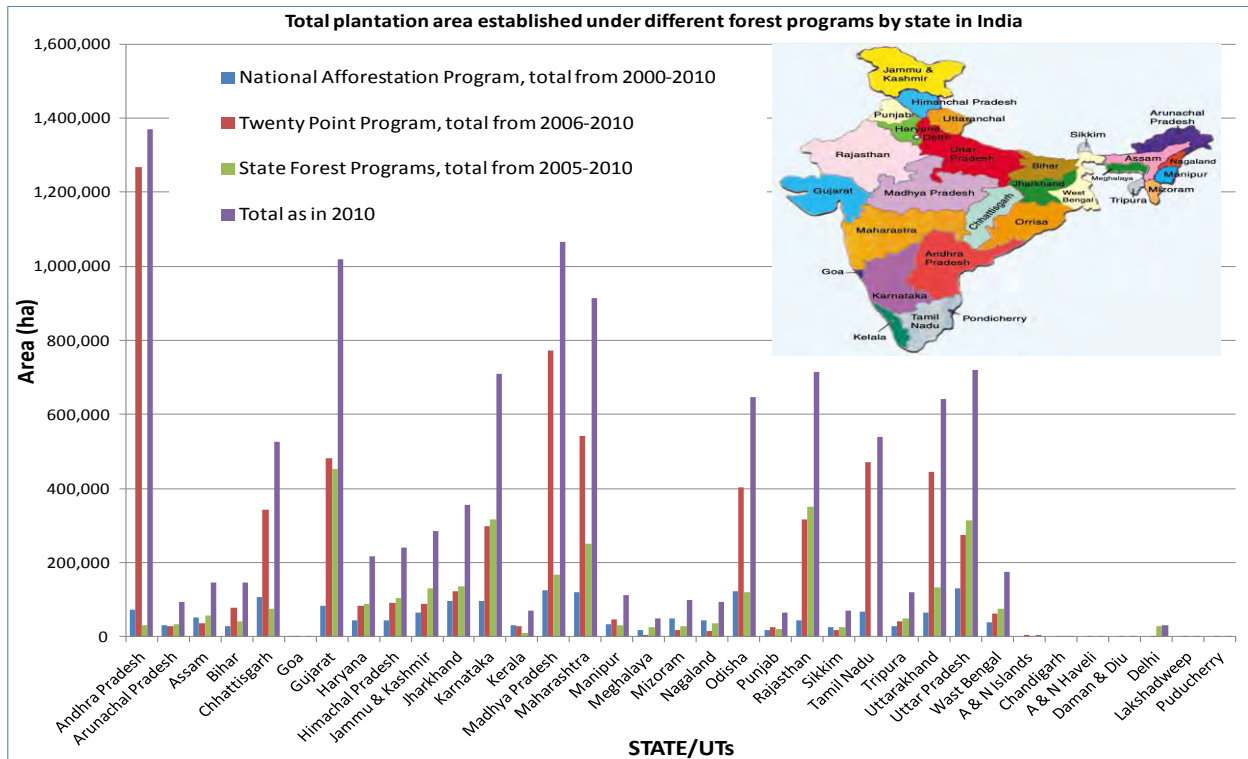

Figure 3. Newly established plantation area total under different programs by state, 2000-2010.

Teak industrial forest area in India is also very significant. Most plantations (2 Mha) were planted in Maharashtra, Madhya Pradesh, Andhra Pradesh and Gujarat states (ICFRE, 2010). The majority of rubber plantations (0.7 Mha) were established in Kerala state (~90%); the fast-growing species plantations such as *Eucalyptus* and *Acacia* spp. were mainly developed in the key pulp & paper production centers such as Andhra Pradesh, Karnataka, Maharashtra, Gujarat, and Orissa states.

In brief, the plantation area in India is very significant and is expanding it quickly. Most of new tree plantations are fast-growing short-rotation species such as eucalypts, acacias, & pines while teak is the most significant long-rotation species. However, the comprehensive and adequate statistical data such as newly expanded area and location for different species in different states and the whole country are very limited and not verified yet.

INDONESIA

Indonesia is also one of the most significant plantation forest countries in the world. The ITTO (2009) estimated the total area of plantations in Indonesia about 10 Mha in 2005. Of that, the Indonesia’s commercial IF plantation area totalizes about 4.9 Mha with 1.5 Mha of teak, followed by 1 Mha of rubber, 0.8 Mha of pines, 0.7 Mha of acacias, 0.2 Mha of eucalypts, and 0.9 Mha of the other species (Figure 4). The area of fast growing species plantations in Indonesia increased rapidly from 2.2 to 3.4 Mha between 1990 and 2005 (FAO, 2005). Over the same period, the area of rubber plantations also increased from 1.9 to 2.7 Mha.

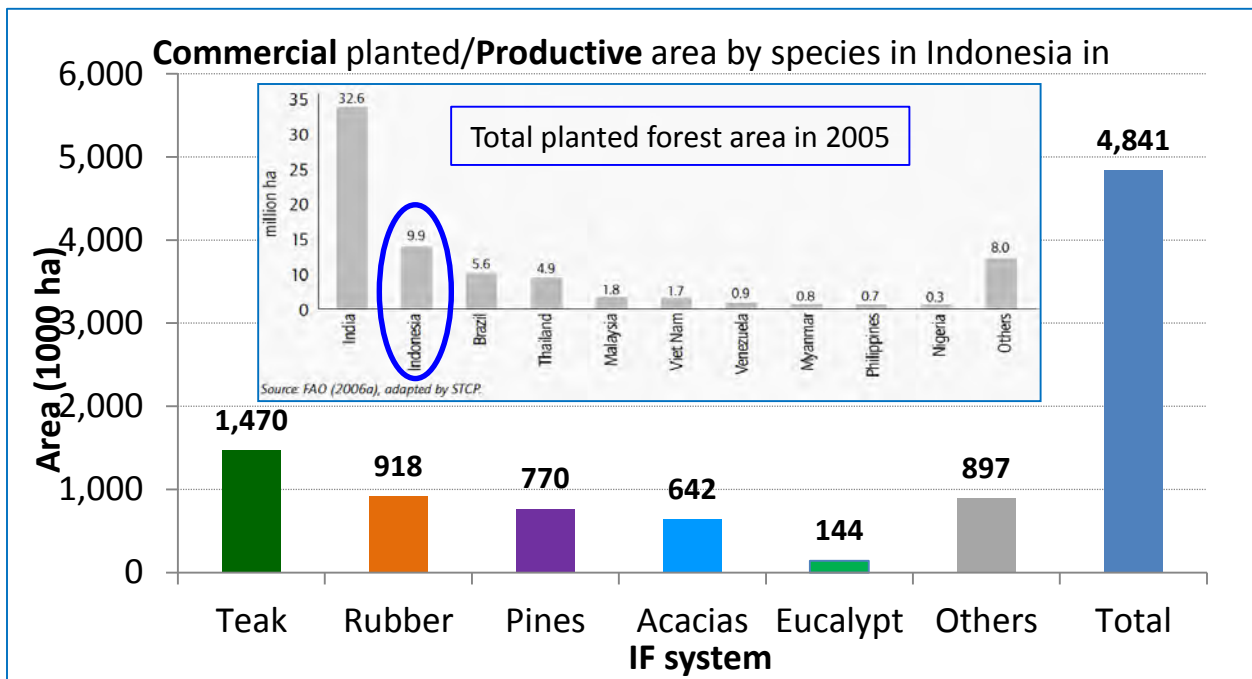

Figure 4. The commercial plantation area in Indonesia in 2005 (source: ITTO, 2009).

The Indonesia Forestry Statistical Data shows that the total industrial timber plantation area (HTI) has increased from 5.1 Mha in 2001 to 9.4 Mha in 2009, and 13.1 Mha in 2012 (Figure 5). Most of these plantations are located in East Kalimantan, West Kalimantan, Riau, and South Sumatra. The provinces East Kalimantan (light yellow in Figure 5), West Kalimantan (purple), and Papua (light blue) show the biggest expanded IF area in the period (Figure 5).

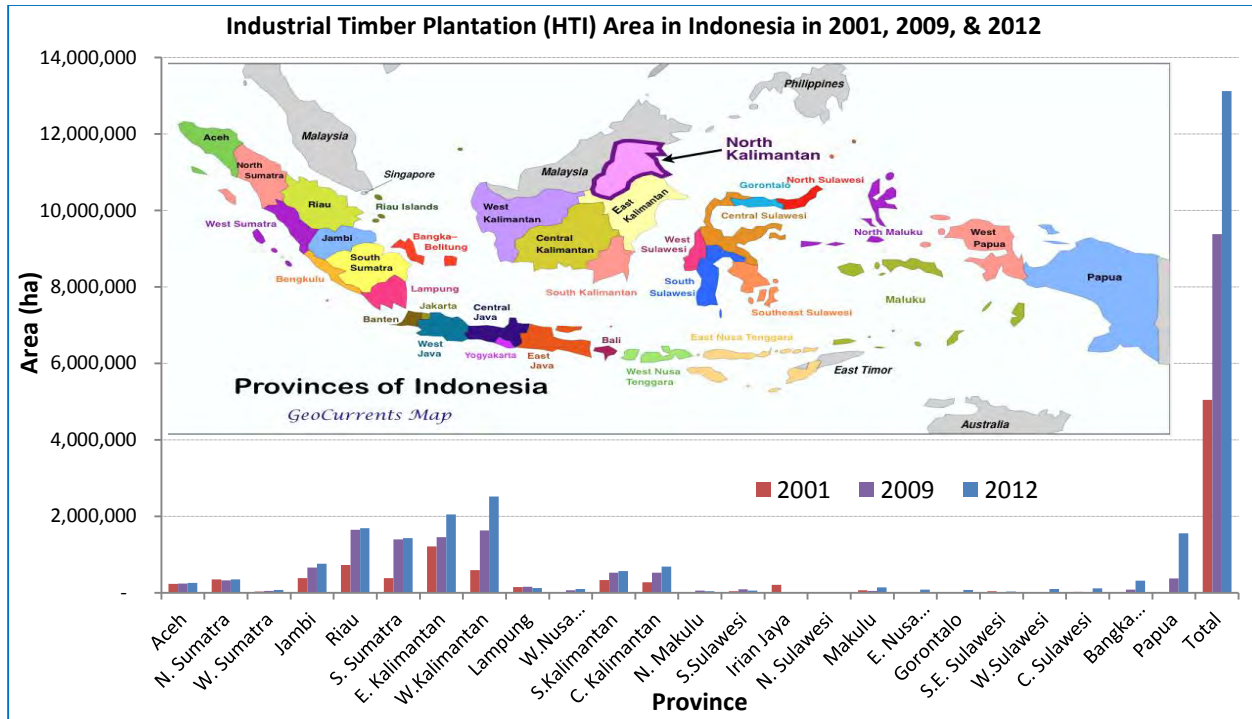

Figure 5. The industrial timber plantation area in Indonesia, 2001, 2009, and 2012.

A study by [FAO \(2009\)](#) also indicated the locations of the largest pulpmills and their material sources ([Figure 6](#)). [Barr \(2007\)](#) noted that 80% pulp industrial plantations were *Acacia* spp., with some *Pinus* and *Eucalyptus* spp.; sawnwood IFs are mainly teak and other broadleaved species.



Figure 6. The distribution of pulp and sawnwood plantations in Indonesia (source: [FAO, 2009](#)).

While most of state company-owned [teak](#) plantations (~1.8 Mha) were mainly established on Java island, the private company-owned [teak](#) plantations (1 Mha) were developed in Sumatra and Kalimantan island ([Indonesia Forestry Outlook Study, 2009](#)). Likewise, the private smallholder-owned rubber plantations (more than 3 Mha) were mostly established in Sumatra and Kalimantan islands. Indonesia also plans to have 9 Mha more of industrial timber plantations by the end of 2016. Most of the new IF areas will be established in Papua (1.7 Mha), East Kalimantan (1.5 Mha), West Kalimantan (1 Mha), Riau (1.2 Mha), and South Sumatra (1 Mha).

In brief, the industrial forest area of Indonesia covers a large area and is being quickly expanded. However, it is lacking comprehensive studies about new IFs as a new Land Use Land Cover Change (LULCC) phenomenon in the country. Therefore, it poses a need for studying the industrial forests as a new LULCC.

THAILAND

Thailand's plantation area total was estimated 4.0-4.9Mha in 2005 depending on sources ([Blasser et al., 2011](#); [FAO, 2010](#); [ITTO, 2009](#)). The [ITTO \(2009\)](#) estimated Thailand had the total commercial plantation area about 4.9 ha including [rubber](#) (2 Mha), [teak](#) (0.8 Mha), [pines](#) (0.7 Mha), [eucalypts](#) (0.45 Mha), [acacias](#) (0.15 Mha), and other species (0.75 Mha) ([Figure 7](#)).

[Rubber IFs](#) keep a very important position in Thailand's wood-based industries. They are mainly owned by smallholders (93%) and are located mostly Southern Thailand (>80%). The data from the [Forest Resources Assessment \(FAO, 2010\)](#) indicated that rubber plantation area of Thailand increased from 2 Mha in 2000 to 2.6 Mha in 2010. However, according to Rubber Statistics of Thailand ([2011](#)), in 2011, Thailand had approximately 3 Mha, an increase of 0.2 Mha from 2009. The rubber distribution varies across regions in Thailand ([Figure 8](#)).

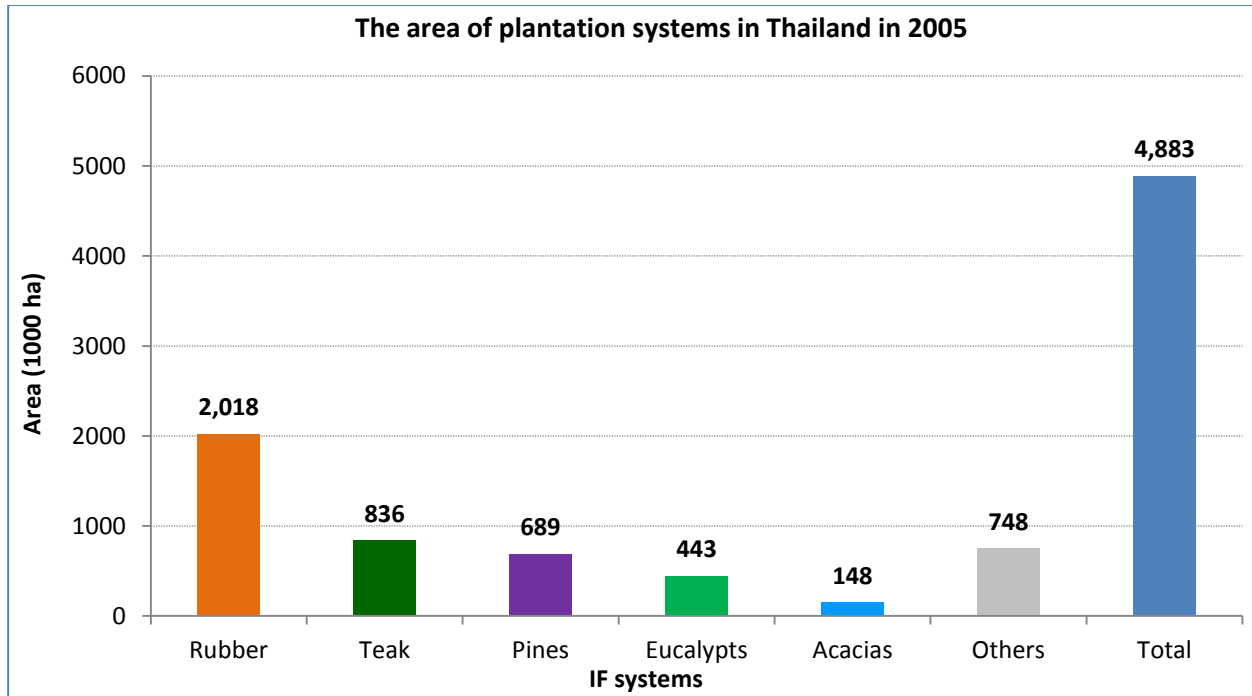

Figure 7. Thailand commercial plantation area in 2005 (source: ITTO, 2009).

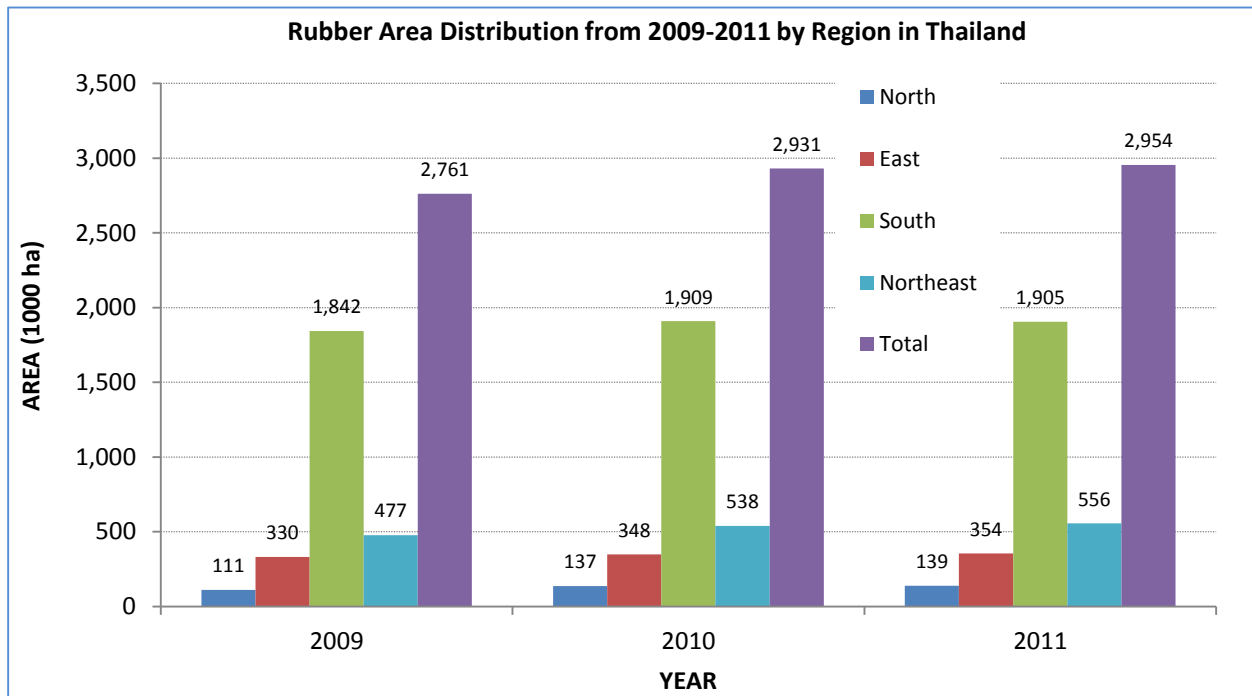

Figure 8. Thailand rubber distribution in different regions (source: Thailand Rubber Statistics, 2011).

Pulpwood IFs (mainly dominated by *Eucalyptus* spp. and some *Acacia* spp.) were principally established by private companies, smallholders, and governmental entities, especially smallholders who hold most of pulpwood plantations in Thailand. Barney (2005a) indicated most of *Eucalyptus* plantations were established in the northeastern area of the country (~50 %) (Figure 9), with almost two thirds of the total *Eucalyptus* plantations based in Thailand managed by smallholders who participated in private company extension programs.

Teak and *Pinus* IFs in Thailand are also very significant. However, the information on them is very scarce. Teak was reported to be mainly established in agrosystems by governmental entities in the Northeast and North. *Pinus* IFs were predominantly planted in the North, but they tend to be older plantations starting in the 1960s (Oberhauser, 1997). It is unclear where and how much of these plantations are newly established because of limits of available information and data.

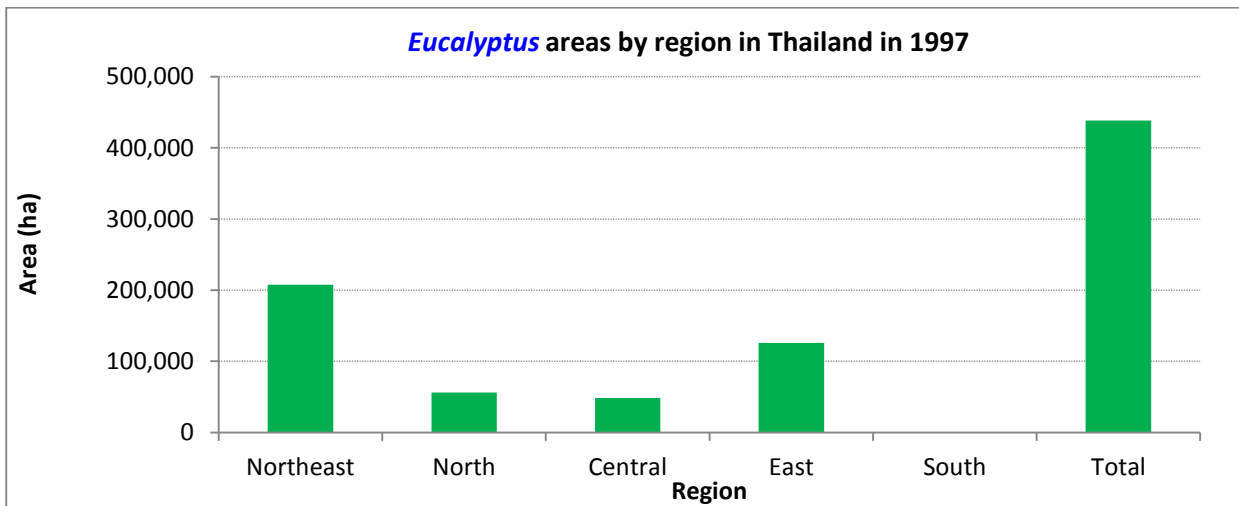

Figure 9. The distribution of *Eucalyptus* plantations by region in Thailand in 1997 (source: Barney, 2005a).

In brief, Thailand also has a very significant IF area, especially rubber, teak and pines. However, the IF data in Thailand is very limited.

MALAYSIA

Along with India, Indonesia and Thailand, Malaysia is also one of the significant plantation tropical countries over the world. The ITTO (2009) estimated Malaysia’s total commercial plantation area around 1.8 Mha in 2005 including rubber (1.5 Mha), followed by *Acacia* spp. (0.2 Mha), *Pinus* spp. (0.06 Mha), *Eucalyptus* spp. (0.02 Mha), *teak* (0.01 Mha), and other species (0.01 Mha) (Figure 10). Most of rubber plantations of the country are established in Peninsular Malaysia while other IF plantations are developed in Sarawak and Sabah (Figure 11).

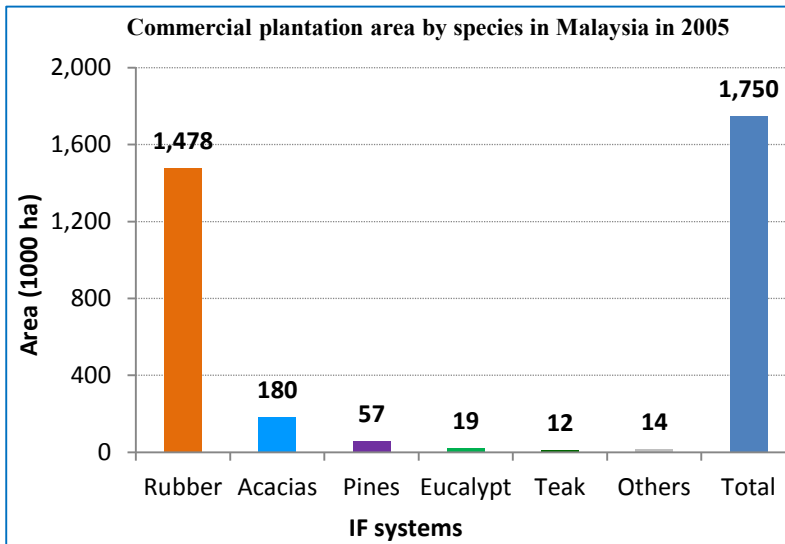

Figure 10. The commercial plantation by species in Malaysia in 2005 (ITTO, 2009).

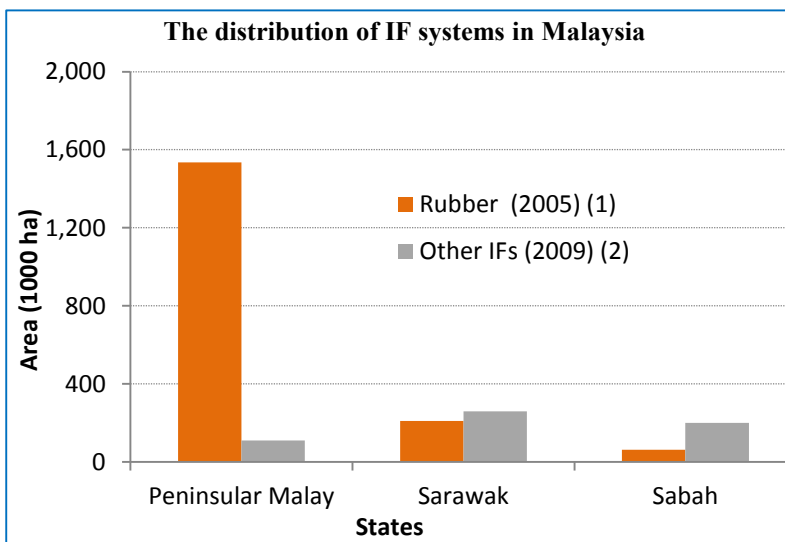

Figure 11. The distribution of plantations (rubber in 2005 & other plantations in 2009) in Malaysia (adapted from (1) Malik *et al.*, 2013; (2) Malaysia Timber Council, 2009).

However, the [Malaysian Ministry of Plantation Industries and Commodities/MPIC](#) reported a total [rubber](#) plantation area of approximately 1.0 Mha in 2013, significantly declining from 1.4 Mha in 2000, and 1.2 Mha in 2005 ([MPIC, 2013](#))¹.

[Pulpwood IFs](#) in Malaysia are mainly *Acacia* spp. and are being quickly expanded in Sarawak ([Figure 12](#)) and Sabah. This is because the Government has identified that the pulp and paper industry is one of priority areas in the new National Economic Development Plan. Sabah and Sarawak states will be key pulpwood production centers of the country in this plan ([Malaysia Forestry Outlook Study, 2009](#)). As a result, Sabah also has set a target to establish 0.5 Mha of forest plantations by the year 2020, while Sarawak is expected to have a total of 1.2 Mha by 2020. In addition, the Federal Government has also launched a new plan to establish 375,000 ha of new forest plantations, giving priority to [rubberwood](#) and *Acacia* spp. (mainly *Acacia mangium* and [hybrid](#)), in the next 15 years at an expected annual planting rate of 25,000 ha. Another plan covers more 0.5 Mha ([Malaysia Forestry Outlook Study, 2009](#)).

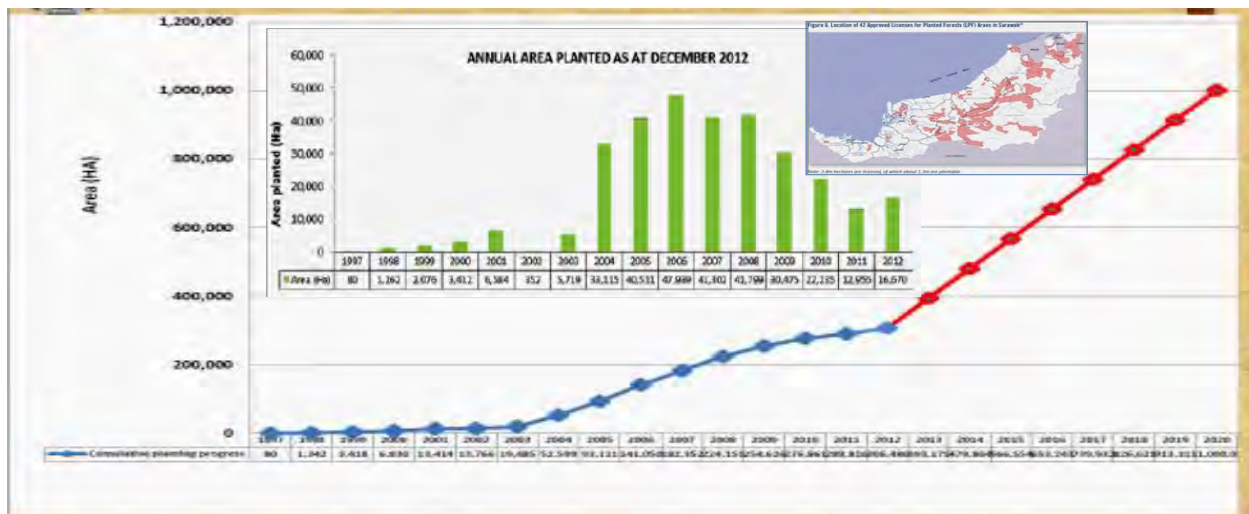

Figure 12. Industrial plantation development in Sarawak, 1997-2012 ([Sarawak Statistics, 2012](#)).

¹ http://www.kppk.gov.my/statistik_komoditi/Data%20Komoditi/general/planted%20071013.pdf

VIET NAM

Viet Nam is among a few countries in the world that have significantly accomplished a net gain in forest area recently. The recovery of Viet Nam’s forests mainly resulted from policies on expansion of new tree plantations and forest rehabilitation. The [FAO \(2000\)](#) estimated the total plantation area of Viet Nam about 1.7 Mha including *Eucalyptus* plantations (0.45 Mha), followed by rubber (0.3 Mha), pines (0.25 Mha), acacias (0.13 Mha), and other species (0.6 Mha) ([Figure 13](#)). The [FAO \(2005\)](#) also showed the trends of the IF area used for pulpwood/fiber and sawlogs was 0.56 Mha in 1990, which increased to 1.2 Mha by 2000, and 1.5 Mha by 2005.

Currently, Viet Nam’s plantation forest area total is about 3.4 Mha, significantly increased from 1.9 Mha in 2002 ([Figure 14](#)) ([MARD, Decision 1739, 2012](#)). Of that, the total IF production plantation area was 2.5 Mha. The production plantations were mainly located in the North East, North Central, and South Central Coast/Coastal regions of Viet Nam ([Viet Nam Forestry Outlook Study, 2009](#)). These regions are considered as the main material suppliers to the pulp, paper, artificial board, and chip production industries in Viet Nam.

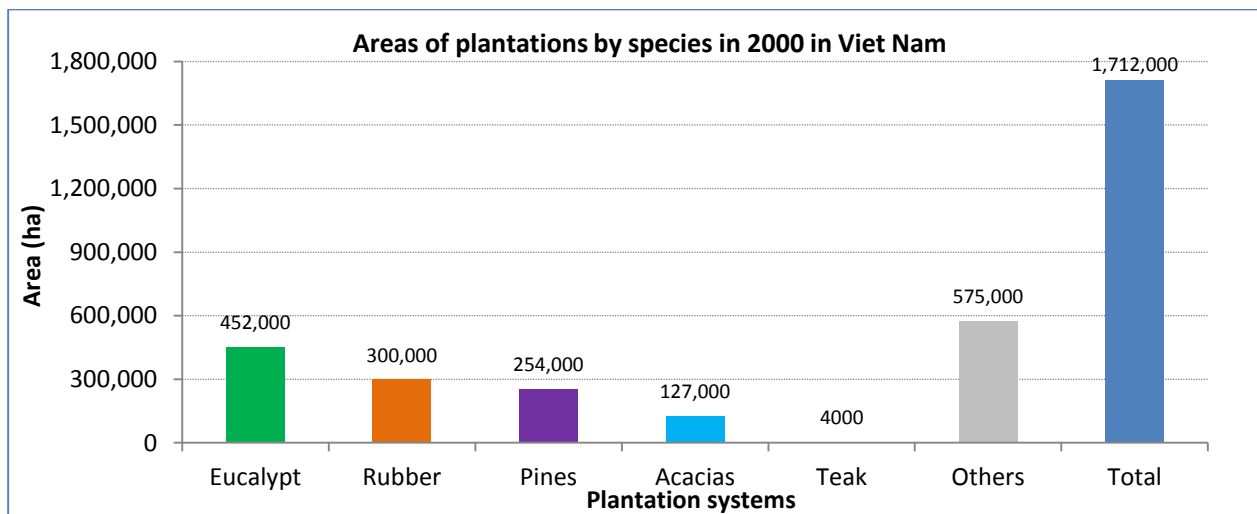

[Figure 13](#). Plantation area by species in 2000 in Viet Nam (source: [FAO, 2000](#)).

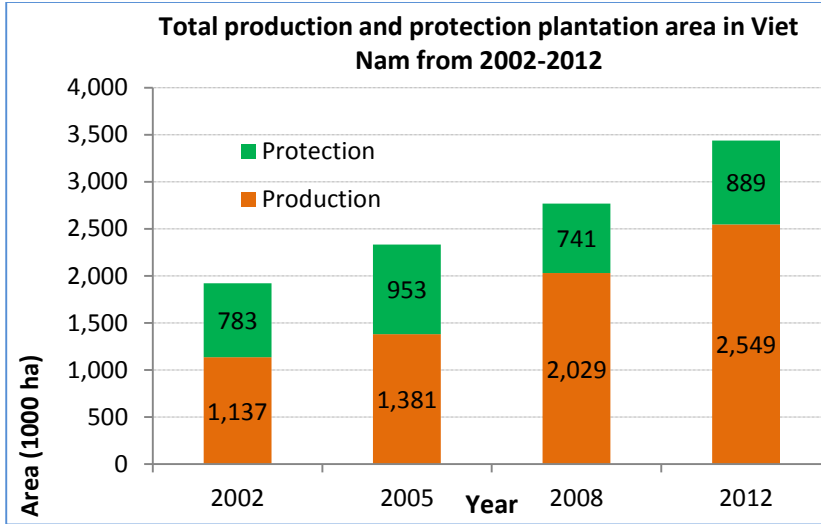

Figure 14. Total plantation area by type (production vs. protection) from 2002 to 2012 in Viet Nam (source: Ministry of Agriculture and Rural Development/MARD, Decision 1739, 2012).

The report of the Ministry of Agriculture and Rural Development (2010) shows the biggest plantation area in 2009 was found in the North East (1 Mha), followed by North Central (0.7 Mha), and South Central Coast/Coastal Region (0.4 Mha) (Figure 15).

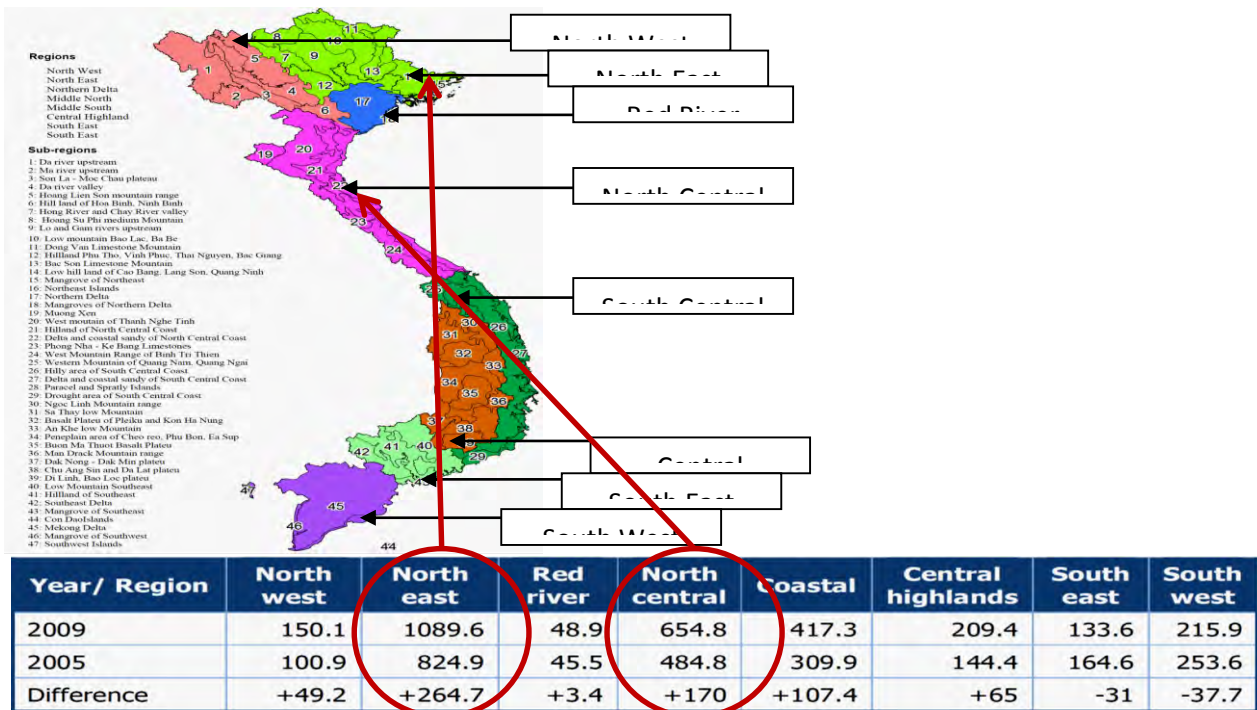

Figure 15. The development of forest plantations (10³ ha) by region, 2005 to 2009, in Viet Nam.

Viet Nam is also a significant natural rubber producer. Luan (2013) reported at the end of 2012, the total rubber area was 910,500 ha, increasing from 410,000 ha in 2000 to 480,000 ha in 2005, 620,000 ha in 2008, and to more than 900,000 ha in 201. The average growth rate in the 2000-2012 period was 6.8%/year. Most of rubber plantations are distributed in the South East region and Central Highlands (Figure 16).

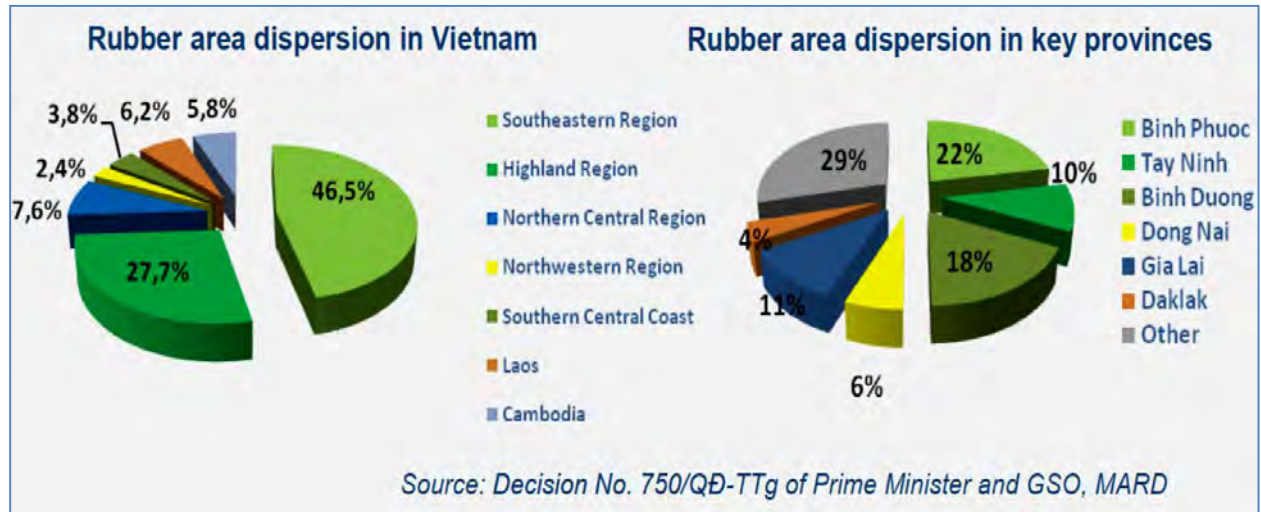

Figure 16. The distribution of Viet Nam's rubber plantations (source: Luan, 2013).

Pulpwood IFs, including *Eucalyptus*, *Acacia*, and *Pinus* spp., were about 1 Mha in 2005 (Barney, 2005b). The Government of Viet Nam plans to establish approximately 1.4 Mha in the 2006-2020 Viet Nam Pulp & Paper Industry Sector Development Strategy, including 600,000 ha in the North East, 325,000 ha in the South Central Coast/Coastal Region, 225,000 ha in the North West, 174,000 ha in the North Central Coast, and 150,000 ha in the Central Highlands. The 2006-2020 Viet Nam Forestry Sector Development Strategy also identified North East, South & North Central Coast as key production centers for wood-based industries. In brief, the forest plantation programs in Viet Nam are principally relying on *Eucalyptus*, *Acacia*, and *Pinus* spp., and rubber. The total teak IF area is not significant (Figure 13).

1.2. Analytical Assessment of Forest Investment and Policy Targets for Production Areas: Forest Policy Assessment in the Targeted Countries (Task 2)

As noted in the proposal, two important megatrends are having a transformational impact on global LCLUC:

- 1) A global investment and policy shift toward biomass-based fuels and biomass feed stocks, driven by concerns over climate change, as well as declining supplies of fossil fuels for energy and materials, and
- 2) Growing economic importance of a rapidly rising demand and associated emerging markets for natural resources, particularly in Asia (cf. China and India).

Task 2 relates to these trends; it is an analytical assessment of forest investment and policy targets for production areas. Dr. Larry Leefers (MSU) has the lead on this task. The focus is on developing assessments for India, Indonesia, Thailand, Malaysia, and Vietnam. Then the individual assessments will be synthesized into a comparative paper. Further, Task 2 finding will be used in the pattern-to-process analysis in Task 9 which will link industrial forest change to policies and investments across the region.

An initial desk study was completed by Mr. Uy Duc Pham (PhD graduate student, Michigan State University). The report is titled “Determining the Pilot Study Areas/ Developing Pilot Projects for Methods Development, TASK 2—Analytical Assessment of Forest Investment and Policy Targets for Production Areas.” A number of country-specific policies have been enacted to encourage the establishment and expansion of forest plantations.

For example, in Viet Nam, policies include:

- Law on Forest Protection and Development, 2004;

- Resolution No. 73/2006/ QH11 on adjustment of the targets and tasks of the project/programme on planting 5 million hectares of forests;
- 2001-2010 Forestry Sector Development Strategy;
- 2006-2020 Viet Nam Forestry Sector Development Strategy and its approval Decision No. 18/2007/QD-TTg; and
- Decision No. 147/2007/QD-TTg for the development of production forests in the period 2007-2015.

Important laws and policies for the development of plantations in Indonesia recently include:

- Law 22.1999 for Regional Governance;
- Law 41.1999 for Forestry;
- National Forest Programme, 2000;
- Indonesia's Social Forestry Program, 2004;
- Policies on Pulp and Paper Industries to self-supply their wood material needs from 2009 onward;
- Reforestation Funds and the Industrial Timber Estate Program to promote private investments on industrial timber plantations to expand the plantation area to 10 Mha by 2030;
- Program on conversion of 4.4 Mha unproductive lands to short-rotation plantations;
- 2006-2016 Industrial Community Forest Plantation Plan (5.4 Mha); and
- Indonesia's National Long Term Forestry Plan with a target of establishing 14.5 Mha timber plantations by 2025.

Examples of important policies for the development of Malaysia's plantations include:

- National Forestry Policy, 1978; amended in 1992;
- National Forestry Act, 1984; amended 1993 (in Peninsular Malaysia);

- Wood-Based Industries Act, 1984 (in Peninsular Malaysia);
- State Forest Enactment 1968 with its subsidiary of Forest Rules, 1969; amended 1992 (in Sabah);
- Forest Ordinance, 1954; amended 2001 (in Sarawak); and
- The Planted Forests Rules, 1997 (in Sarawak).

Similar policies are in place across the region. The initial findings noted above provide a starting point for more in-depth studies of each country. This task involves collaboration with colleagues (experts) in project countries (Table 1). Dr. Leefers met with Professor Abd Ghani in Kuala Lumpur in late 2014 and developed a report outline to be applied across all countries (Figure 17). Draft reports for each country will be developed using this template.

Table 1. Research collaborators on context and drivers of plantation change, by country.

Country	Collaborator
India	Mr. Swapan Mehra, Iora Ecological Solutions
Indonesia	Mr. Yusuf Bahtimi, MS graduate student, Michigan State University
Malaysia	Prof. Awang Noor Abd Ghani, Universiti Putra Malaysia
Thailand	To be determined (TBD)
Vietnam	TBD

Forest Extent and Tenure Ministries/Agencies Involved National and Provincial/State Government Rights Customary Rights Other Private Rights (smallholders, <i>etc.</i>) Trends in Plantation Establishment Geographic Distribution Species (Acacias, Eucalypts, Pines, Rubber, and Teak)—include Oil Palm for comparison Planned IF investments Industry Structure and Location Markets—National and International End users Product Differentiation Marketing Programs Projections Competiveness of IF versus Alternative Uses Price trends Other land-use trends (<i>e.g.</i> , oil palm) Policies

Land use
Taxes
Loans
Incentives
Priority species for investment
Investments
Domestic
International
References
Key contacts

Figure 17. Country-specific context and drivers of industrial forest (IF) plantation change.

1.3. Determination of the Pilot Study Sites (Task 3)

The criteria for selecting the pilot study sites under this project are:

- (1) *Selected species*: the areas should contain most of the selected species or the targeted plantation/IF systems (i.e., *Eucalyptus*, *Acacia*, *Pinus* spp., *teak*, and *rubber*).
- (2) *Area*: the selected sites should show the largest or very significant new IFs area.
- (3) *Dynamics*: the areas should indicate the highest or a very significant rate of change in new IF area, and
- (4) *Policy and investment targets*: key production centers and other policy factors should be considered.

Based on these criteria, the following locations are selected to recommend for the pilot study sites for the project in the targeted countries.

INDIA

A synthesis (Figure 18 and Table 2) was completed indicating that one pilot study site in India should be located in Andhra Pradesh state (Figure 19) because this state shows the highest newly established area and expansion rate in area (ha/year) in the most recent years (2000-2010) under different plantation programs. This state is also one of the key pulpwood production centers of the country with the domination of *Eucalyptus* and *Acacia* species.

Another pilot study site should be in Madhya Pradesh state (Figure 19) because it presents the second largest newly established area and second highest expansion rate in area (ha/year), also in the period of 2000-2010 under different plantation programs. Moreover, this state is one of the key teak production regions of India.

Doing the research in these states will well fit the objectives of the study and answer the research questions posed in this project.

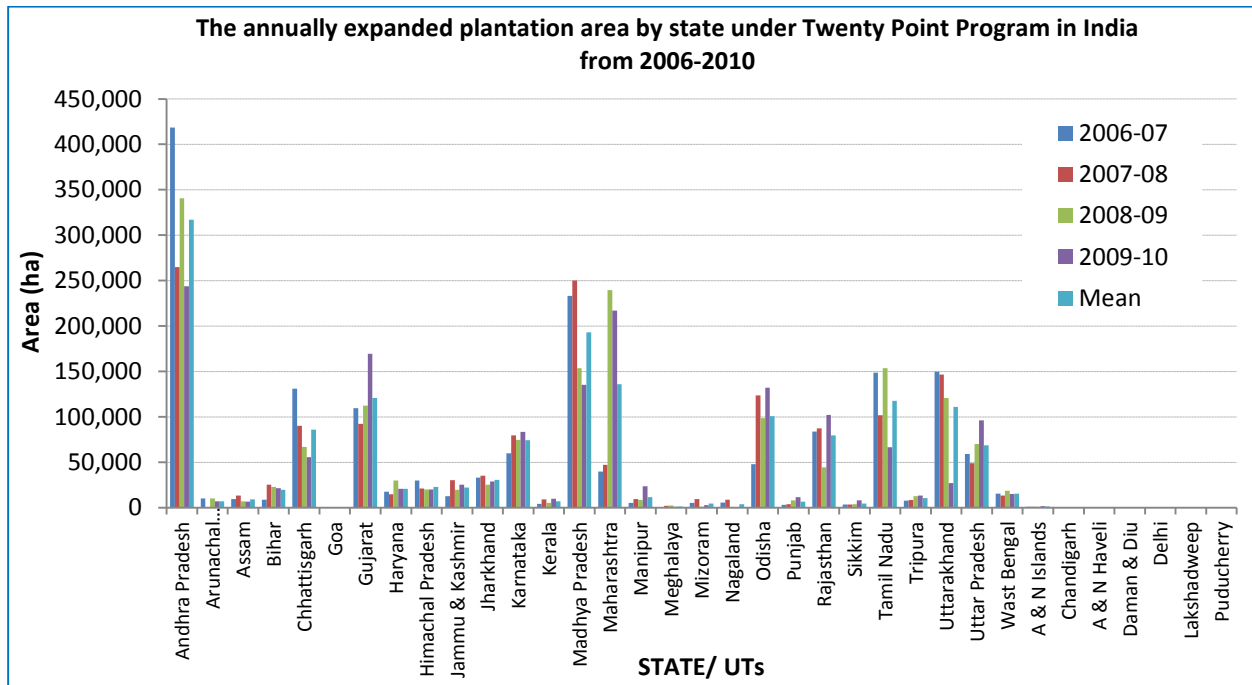

Figure 18. The annual expansion rate under 20-point program in India from 2006-2010.



Figure 19. Map of India showing the Andhra Pradesh (red) and Madhya Pradesh (purple).

Table 2. The summary of India's new plantation area and rate by state from 2000-2010.

NO	STATE/ UNION TERITORIES	Newly Established Plantations Under Different Programs										Plantation Statistics Area Planted (in ha) (4)					
		National Afforestation Program from 2000-2010 (1)		Twenty Point Program (2) 2006-2010					State Forest Departments Programs, total from 2005-2010 (3)			Total 3 Progs in 2010	Other Statistical Data Sources from State Forest Department (1)				
		Total area	Mean rate / year	2006- 07	2007- 08	2008- 09	2009- 10	Total	Mean rate / year	Total area	Mean rate / year		2006- 07	2007- 08	2008- 09	2009- 10	Total
1	Andhra Pradesh	72,823	7282.3	418,480	264,990	340,560	243,930	1,267,960	316,990	30,350	6,070	1,371,133			498,031		498,031
2	Arunachal Pradesh	30,321	3032.1	10,120	550	10,270	7,120	28,060	7,015	34,750	6,950	93,131	7,699	7,769	9,039	4,170	28,677
3	Assam	52,605	5260.5	9,660	13,360	7,110	6,630	36,760	9,190	57,300	11,460	146,665	12,812	13,940	12,864	4,805	44,421
4	Bihar	28,481	2848.1	8,760	25,370	22,750	21,360	78,240	19,560	41,150	8,230	147,871	11,851	10,184	10,449	6,695	39,179
5	Chhattisgarh	106,660	10666	131,210	90,100	66,760	55,510	343,580	85,895	76,200	15,240	526,440	12,768	17,345	18,851	14,706	63,670
6	Goa	1,250	125	480	500	490	370	1,840	460			3,090					
7	Gujarat	82,530	8253	109,450	92,160	112,240	169,350	483,200	120,800	452,300	90,460	1,018,030	83,128	78,024	104,874	135,428	401,454
8	Haryana	44,189	4418.9	17,550	14,780	29,990	20,770	83,090	20,773	89,000	17,800	216,279	17,006	14,739	28,921	9,800	70,466
9	Himachal Pradesh	44,883	4488.3	30,070	21,160	20,100	20,170	91,500	22,875	104,150	20,830	240,533	24,738	19,663	20,447	20,165	85,013
10	Jammu & Kashmir	65,494	6549.4	12,530	30,420	19,750	25,430	88,130	22,033	130,950	26,190	284,574	26,118	28,110	5,379	24,229	83,836
11	Jharkhand	96,500	9650	33,230	35,120	25,180	28,950	122,480	30,620	137,300	27,460	356,280	24,190	29,381	196,800	13,567	263,938
12	Karnataka	96,155	9615.5	59,760	79,470	74,640	83,640	297,510	74,378	316,200	63,240	709,865	64,190	66,430	68,657	80,412	279,689
13	Kerala	31,981	3198.1	4,350	9,040	5,380	9,940	28,710	7,178	10,700	2,140	71,391	2,840	1,323	1,993	2,500	8,656
14	Madhya Pradesh	124,782	12478.2	233,100	250,000	153,750	135,140	771,990	192,998	168,800	33,760	1,065,572	6,446	16,467	10,052	125,623	158,588
15	Maharashtra	119,227	11922.7	39,840	47,020	239,650	216,890	543,400	135,850	251,750	50,350	914,377	41,224	46,772	69,454	57,546	214,996
16	Manipur	35,144	3514.4	5,370	9,430	8,470	23,670	46,940	11,735	30,600	6,120	112,684	1,178	11,002	10,213	6,399	28,792
17	Meghalaya	18,245	1824.5	110	2,070	2,550	1,100	5,830	1,458	26,250	5,250	50,325	5,457	6,761	5,589	4,354	22,161
18	Mizoram	50,120	5012	5,120	9,490	1,050	2,980	18,640	4,660	29,900	5,980	98,660	4,155	6,600	8,850	5,350	24,955
19	Nagaland	43,718	4371.8	5,550	8,780	870	0	15,200	3,800	35,650	7,130	94,568	14,008	3,990	3,800	3,650	25,448
20	Odisha	123,307	12330.7	48,020	123,650	98,790	132,130	402,590	100,648	121,150	24,230	647,047	1,175	62,614	20,482	18,067	102,338
21	Punjab	18,109	1810.9	3,060	3,860	8,120	11,550	26,590	6,648	20,550	4,110	65,249	3,118	3,970	5,346	5,465	17,899
22	Rajasthan	45,490	4549	83,860	87,430	44,360	102,210	317,860	79,465	351,050	70,210	714,400	83,898	87,433	44,365	75,475	291,171

23	Sikkim	26,003	2600.3	3,550	3,450	3,860	8,010	18,870	4,718	26,900	5,380	71,773	3,550	3,457	3,862	8,007	18,876
24	Tamil Nadu	68,192	6819.2	148,810	101,790	153,730	66,450	470,780	117,695		0	538,972			4,760		4,760
25	Tripura	29,470	2947	7,590	8,420	12,600	13,230	41,840	10,460	49,100	9,820	120,410	7,798	10,770	11,214	13,212	42,994
26	Uttarakhand	65,576	6557.6	149,700	146,430	120,850	27,160	444,140	111,035	132,900	26,580	642,616	28,829	28,829	25,727	20,945	104,330
27	Uttar Pradesh	130,127	13012.7	59,220	48,910	70,220	96,070	274,420	68,605	314,750	62,950	719,297	56,956	47,202	94,427	79,177	277,762
28	Wast Bengal	38,248	3824.8	15,380	13,390	18,630	15,040	62,440	15,610	75,850	15,170	176,538	15,382	13,388	18,707	15,043	62,520
29	A & N Islands			1,080	910	1,210	1,740	4,940	1,235	1,500	300	6,440	867				867
30	Chandigarh			180	240	380	180	980	245	1,200	240	2,180					
31	A & N Haveli			220	200	280	200	900	225			900					
32	Daman & Diu			10	30	30	20	90	23			90					
33	Delhi			0	80	80	120	280	70	30,050	6,010	30,330	5,958	6,350	5,720	6,907	24,935
34	Lakshadweep			0	0	20	20	40	10			40					
35	Puducherry			190	80	50	50	370	93			370					
Subtotal				1,655,610	1,542,680	1,674,770	1,547,130	6,420,190				567,339	642,513	1,318,873	761,697		3,290,422
TOTAL		1,689,630						6,420,190	3,148,300			11,258,120					3,290,422

Note: The data is synthesized from the following sources:

(1): Forest Sector Report India 2010, Apendix 4.2, page 86, India Council of Forestry Research and Education

(2): Forestry Statistics India, 2011, Section 5, Table 5.5, page 68, India Council of Forestry Research and Education

(3): Forest Sector Report India 2010, Apendix 4.9, page 102, India Council of Forestry Research and Education

(4): Forestry Statistics India, 2011, Section 1, Table 1.4, page 14, India Council of Forestry Research and Education.

The main IF species are planted in key IF states as follows. **Andhra Pradesh:** *Eucalyptus* spp., *teak* and others; **Gujarat:** *Acacia* and *Eucalyptus* spp., *teak* and others; **Madhya Pradesh:** *teak* and others; **Karnataka:** *teak* and *Eucalyptus* spp.; **Maharashtra:** *teak* and others; **Odisha/Orrisa:** *Eucalyptus* spp., *teak* and others; **Uttar Pradesh:** *teak*, *eucalypts* and others.

INDONESIA

An analysis for Indonesia industrial forest development (Table 3) was also conducted to determine the pilot study sites based on the abovementioned criteria. Based on this analysis, we selected one pilot study site in East Kalimantan province (Figure 20). It is a key industrial timber production center with the second largest plantation area of the country. At the same time, it shows very high rate and magnitude of change in IF plantation area. It also presents good accessibility, and we are doing some studies there.

Another pilot study site will be in either Papua or West Kalimantan province (Figure 20) because they are emerging as a new important production center with a very high rate of change in the IF area. They also have a very significant IF area.



Figure 20. Map of Indonesia showing the selected pilot study sites: East Kalimantan (light yellow); West Kalimantan (purple) or Papua (light blue).

Table 3. The summary of Indonesia's new plantation area and rate by province from 2009-2012

PROVINCE	Species	Area (ha)		Difference for the period	Rate of change (% and ha/year)	
		2009	2012	ha	%/year	ha/year
Aceh	Pulpwood & others	241,170	254,308	+ 13,138	1.8	4,379
N. Sumatra	Pulp, sawnwood, rubber	321,732	346,212	+ 24,480	2.5	8,160
W. Sumatra	Unknown	50,649	73,204	+ 22,555	14.8	7,518
Jambi	Pulp, sawnwood, rubber	663,809	756,977	+ 93,168	4.7	31,056
Riau	Pulp, sawnwood, rubber	1,645,301	1,692,776	+ 47,475	1.0	15,825
S. Sumatra	Pulp, sawnwood, rubber	1,396,312	1,426,034	+ 29,722	0.7	9,907
E. Kalimantan	Pulp & sawnwood	1,453,967	2,048,685	+ 594,718	13.6	198,239
W.Kalimantan	Pulp, sawnwood, rubber	1,629,256	2,520,577	+ 891,321	18.2	297,107
Lampung	Sawnwood & others	157,044	127,954	-29,090	-6.2	-9,697
W.Nusa Tenggara	Unknown	64,780	98,395	+ 33,615	17.3	11,205
S.Kalimantan	Pulp & sawnwood	527,560	563,992	+ 36,432	2.3	12,144
C. Kalimantan	Sawnwood	526,026	682,990	+ 156,964	9.9	52,321
N. Makulu	Unknown	59,138	44,463	-14,675	- 8.3	-4,892
S.Sulawesi	Sawnwood	88,900	58,375	-30,525	- 11.4	-10,175
N. Sulawesi	Unknown	7,500	7,500	0	0.0	0
Makulu	Sawnwood, others	50,455	144,560	+ 94,105	62.2	31,368
E. Nusa tengara	Unknown	13,375	84,230	+ 70,855	176.6	23,618
Gorontalo	Unknown		75,920	+ 75,920		25,307
S.E. Sulawesi	Unknown		34,052	+ 34,052		11,351
W.Sulawesi	Sawnwood, others	13,300	100,195	+ 86,895	217.8	28,965
C. Sulawesi	Sawnwood, others	13,400	119,942	+ 106,542	265.0	35,514
Bangka Belitung	Unknown	81,375	313,642	+ 232,267	95.1	77,422
Papua	Pulpwood & others	376,200	1,551,829	+ 1,175,629	104.2	391,876
Total		9,381,249	13,126,812	+ 3,745,563	13.3	1,248,521

THAILAND

Although the IF data in Thailand is very limited, we are still somewhat able to paint a overall picture to determine the pilot study sites based on the aforementioned criteria (Table 4). Both pilot study sites should be located in the North East region (Figure 21) because it shows the second highest expansion rate for establishing rubber plantation and has significant area of other IFs. And this region is also the most important pulpwood production center of the country.



Figure 21. Map of Thailand presenting the selected region (North East in pink color) for the pilot study sites.

Table 4. The summary of Thailand's new plantation area and rate by species and regions.

Species	Region	Area (ha)		Difference for the period ha	Rate of change (% and ha/year)		Social & Economic Factors	Note
		2009	2011		%/year	ha/year		
Rubber	North	111,000	139,000	+ 28,000	12.6	14,000	The key rubber production center	(1) 93% rubber plantation in smallholdings; (2) The average size of the plantation being only 2.08 ha
	East	330,000	354,000	+ 24,000	3.6	12,000		
	North East	477,000	556,000	+ 79,000	8.3	39,500		
	South	1,842,000	1,905,000	+ 63,000	1.7	31,500		
	Total	2,761,000	2,954,000	+ 193,000	3.5	96,500		
<i>Eucalyptus spp.</i>		1995	1997				Big pulp & chip mills located	(1) 65% smallholdings (mean farm size at 3 ha); 35% pulp companies, large holders and others; (2) no large/significant pulp project since 1997
	Central & West	14,000	50,000	+ 36,000	129	18,000		
	North	23,000	56,000	+ 33,000	71.7	17,000		
	East	120,000	126,000	+ 6,000	2.5	3,000		
	North East	170,000	208,000	+ 38,000	11.2	19,000		
Total	327,000	440,000	+ 113,000	17.3	57,000			
Other selected species	Teak: no specific data, mainly established by Forest Industry Organization (530,000 ha in 2003) & Royal Forest Department, <i>etc.</i> , in agrosystems, totally in 2005 (836,000 ha)							
	Pinus spp.: no specific data, largely established in the North, totally in 2005 (689,000 ha)							
	Acacia spp.: no specific data, totally in 2005 (148,000 ha)							

MALAYSIA

In Malaysia, based on the data collected and analyzed (Table 5), one pilot study site will be located in Sarawak state (Figure 22) because it shows the biggest selected IF species (not including rubber) area with the highest rate of change in area. It is planned as a key production center for pulp and paper industries with an expectation to have 1.2 Mha in 2020. Another pilot study site will be in Sabah state (Figure 22) because this area also shows a significant area of the timber plantations and high rate of change in their area. It is also planned as a key production center for pulp and paper industries with an expectation to have 0.5 Mha in 2020.

Table 5. A summary of plantation areas and the rate of its change by state in Malaysia.

Species	State	Area (ha)		Difference for the period ha	Rate of change		Social & Economic Factors	Note	Source
		1990 (<i>or</i> 2000)	2005 (<i>or</i> 2009)		%/ year	ha/ year			
Rubber	Peninsular Malaysia	2,279,001	1,535,127	-743,874	-2.2	-49,592	Reported as out- competed by oil palms	(1) Most rubbers owned by smallholders (80-96%); (2) Malaysia Rubber Statistics 2011:~ 1,013,000 Mha	Malik et al. 2013
	Sarawak	152,717 (2000)	209,918	+ 57,201	0.9	11,440			
	Sabah	78,895 (2000)	62,891	-16,004	-4.1	-3,201			
	Total (other statistics)	1,836,700	1,244,600 (2009)	-592,100	-1.7	-31,163			
		Area in year 2000	Area in year 2012						
Other selected IF species (mostly <i>Acacia</i> , some others)	Peninsular Malaysia	74,000	110,000 (2009)	+ 36,000	4.1	3,000	Low potentials for IFs		Outlook Study , 2009
	Sarawak	6,830	306,486	+ 299,656	365.6	24,971	Key production centers for pulp & paper industries	Sarawak plans to have 1.2 Mha & Sabah expects to have 0.5 Mha in 2020	Sarawak Statistics 2012
	Sabah	154,640	244,000	+ 89,360	4.8	7,447			Sabah Statistics, 2012

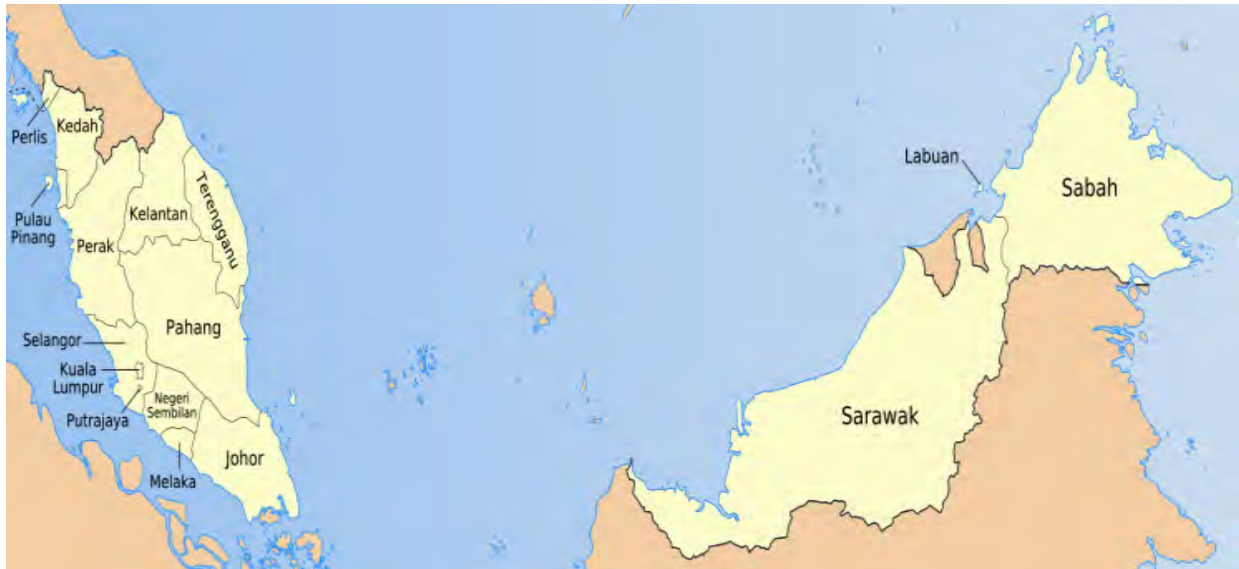

Figure 22. Map of Malaysia showing the selected pilot study sites (Sarawak & Sabah).

VIETNAM

Like the above countries, one synthesis also has been done (Table 6), and one pilot study site will be located in the North East because it shows the biggest IF area, biggest magnitude of change, very high rate of change in area; and another in the Central Highlands because it has the highest rate of change in the plantation area and also has very significant plantation area. This site is dominated by rubber. The 2006-2020 pulpwood development plan identifies both these regions are key production centers.



Figure 23. Map of Viet Nam showing the pilot study sites (North East and Central Highlands).

Table 6. A summary of plantation areas and the rate of its change by regions in Viet Nam from 2005 to 2012.

Region	Species	Area (ha)		Difference for the period ha	Rate of change (% and ha/year)		Social & Economic Factors	Note
		2005	2012		%/year	ha/year		
North West	Mostly <i>Acacia</i> , <i>Eucalyptus</i> , <i>Pinus</i> spp.; some rubber	100,924	176,048	+ 75,124	10.6	10,732	Difficult accessibility	(1) No specific data for species;
North East	Mostly <i>Acacia</i> , <i>Eucalyptus</i> , <i>Pinus</i> spp.; few others	824,938	1,232,032	+ 407,094	7.0	58,156	Key wood production center	(2) Species assumed based Jaakko Poyry (2001) & some other reports;
Red River	Mostly <i>Acacia</i> , <i>Eucalyptus</i> , <i>Pinus</i> spp.	45,503	47,187	+ 1,684	0.5	241	No land availability	(3) Rubber statistics (in 2012) from MARD different from other studies e.g., Luan (2013); Phuc and Luan (2014).
North Central	Mostly <i>Acacia</i> , <i>Eucalyptus</i> spp.; some rubber	484,840	712,015	+ 227,175	6.7	32,454	Key wood production center	
South Central Coast / Coastal	Mostly <i>Acacia</i> , <i>Eucalyptus</i> , <i>Pinus</i> spp.; few others	309,939	545,538	+ 235,599	10.9	33,657	Key wood production center	
Central Highlands	<i>Rubber</i> , <i>Acacia</i> , <i>Eucalyptus</i> , <i>Pinus</i> spp.	144,420	309,950	+ 165,530	16.4	23,647	Fast-growing species are less competitive than rubber and other crops in these regions	
South East	Mostly <i>rubber</i> , some others	164,591	225,784	+ 61,193	5.3	8,742	No land availability	
South West	Mostly <i>Acacia</i> , <i>Eucalyptus</i> , <i>Pinus</i> spp.	253,623	189,647	-63,976	-3.6	-9,139	No land availability	

II. Silvicultural Practice Assessments

A silvicultural practice assessment report has been made for the selected countries by Professor Pascal Nzokou and Patrick Shults (a graduate student at Forestry Department, Michigan State University) as follows:

India: a study by ITTO (2009) indicated that IF productivity was very low due to poor site-species matching, low quality planting stock, and lack of maintenance and protection from pests. Although India has the world second largest plantation area, its growth, survival, and yield rates were far lower than other areas of the world. The fast-growing IF species were reported to occupy 50-75% of total area. Eucalyptus (particularly *E. tereticornis* and *E. grandis*) is the most widely chosen species for short-rotation tree farms. While *E. tereticornis* is generally chosen for wetter, lower elevation areas, *E. grandis* is principally planted in dry, high elevation areas. In general, the IF species selection is mostly dependent on availability of seedlings from the government nurseries and short-term economic return, whereas species-to-site matching is not carefully considered. This is believed a main cause leading to poor IF productivity problems in India. The summary of IF silvicultural practices for the selected species in India is presented (Table 7).

Table 7. The summary of IF silvicultural practices for the selected species in India.

Species/ IF systems	Area (Mha)	Nursery and Establishments	Rotation (Years)	Growth (MAI) (m ³ /ha/year)	Yield (Mm ³ /yr or m ³ /ha)	Assessment/ Note
Eucalypts	2.0	Coppicing/generating stand 1-2 rotations, then replanting, spacing 2*2-4*4 m ² , 1,200-2,500 stems/ha	6-10	5-10	20 Mm ³ /yr	Low production capacity; Mm ³ /yr: Million m ³ /year
Pines	0.6	No data	No data	12	8 Mm ³ /yr	MAI: Mean Annual Increment

Teak	2.6	Mainly vegetative propagation; and seedling, planting 2*2 m at establishment, then thinning 5-6 times finally to 4*4m	20-80, standard rotation of 25 years	2-9	13 Mm ³ /yr	Low productivity
Rubber	0.6	Seedling, no further data	No data	10	6 Mm ³ /yr	No information
Acacia	1.6	No information	No data	8 (possibly reach 10-34 m ³ /ha/yr)	13 Mm ³ /yr	No information

Indonesia: Information regarding silvicultural practices in Indonesia is also very limited. Only the information on teak and acacias is available in depth. This is because of corresponding lack of standard practice across the country and lack of communication among entities. Silvicultural plans in Indonesia vary in specifics according to species, but the far and wide the method for plantation establishment and harvest is artificial regeneration and clearcutting. Rotation lengths also vary but generally speaking 6-8 year rotations are common for pulpwood species (*A. mangium* and *Eucalyptus* spp.) and 40-80 years for teak. Mean annual increments (MAI) of most plantations range between 15-25 m³ per hectare. These numbers are considered to be very low; and thus the Indonesian government is taking measures to improve them. The summary of IF silvicultural practices for the selected species in India is presented (Table 8).

Table 8. The summary of IF silvicultural practices for the selected species in Indonesia.

Species/ IF systems	Area (Mha)	Nursery and Establishments	Rotation (Years)	Growth (MAI) (m ³ /ha/year)	Yield (Mm ³ /yr or m ³ /ha)	Assessment/ Note
Eucalypts	0.2	Limited information	6-10	16-19	No data	Not preferred recently
Pines	0.8	Seedling, transplanting at spacing 2*2-3*3m	15-30	20-30	No data	pulpwood and saw logs
Teak	1.5	Seedling, transplanting and recently sowing at spacing 2*1m at the beginning (3,000	40-80 years	2	100 m ³ /ha	Low productivity

		stems) and thinning to 100-200 stems/ha				
Rubber	1.0	No data	No data	No data	No data	No information
Acacia	1.0	Seedling, transplanting at 2*2 to 4*4m, the most common spacing at 3*3, 4*2, or 4*3m	6-8 years for pulpwood ; 15-20 years for sawn wood	20-34,	60-100 m ³ /ha	Low productivity

Malaysia: IF silvicultural practices in Malaysia also face a number of challenges including species selection, species-to-site matching, germination rates, available planting stock, initial growth rates (for weed control), genetic resistance to insects and disease, and purpose of future product . Selecting IF species and matching them with the sites for an optimal rotation time in specific locations are the initial main concerns for IF silvicultural practices of the country. The IF species in the country are mostly dominated by exotic species. This is mainly due to a high availability of exotic seed as well as high growth rates and yields of exotics over indigenous species. For instance, *A. mangium*, the widest-planted IF fast-growing and short rotation non-native species, is well-known for their vigor and ability to adapt to varying site conditions. Also, there is well documented research concerning its silviculture needs, seeds, establishment, and diseases. The summary of IF silvicultural practices for the selected species in Malaysia is presented (Table 9).

Table 9. The summary of IF silvicultural practices for the selected species in Malaysia.

Species/ IF systems	Area (Mha)	Nursery and Establishments	Rotation (Years)	Growth (MAI) (m ³ /ha/year)	Yield (Mm ³ /yr or m ³ /ha)	Assessment/ Note
Eucalypts	0.02	No data	No data	No data	No data	No data
Pines	0.06	No data	No data			Declining
Teak	0.01	Initial planting spacing at 2*2 to 6*3m. The most common at 2.5*4.5m or 800-1,700	>15 years	7-12	No data	Clear-cut, followed burning and planting

		trees/ha, thinning to 300 stems/ha				
Rubber	1.50	Planting at 700-1,100 trees/ha, then thinning and pruning applied to the final density at 460-570 trees/ha.	25 year	26	60 m ³ /ha of saw logs or ~ 20 m ³ of sawn wood	Clearcut and replanting
Acacia	0.02-0.05	Seedling, planting at the spacing 2*3m, 3*3 or 4m; 4*4m; (~900-1,700 trees/ha). Thinning and pruning applied to the final density at 180 -300 trees/ha.	6-8 years for pulpwood, 15 years for saw logs		250 m ³ /ha	

Thailand: Species selection in Thailand today depends largely on survival rates, ability for rapid growth, density and crown spread (to shade out weeds), and ability to coppice. Rubber is far and away the most popular species of choice for industrial timber destined for different purposes including production of wood only, latex and wood, and latex only. The summary of IF silvicultural practices for the selected species in Thailand is presented (Table 10).

Table 10. The summary of IF silvicultural practices for the selected species in Thailand.

Species/ IF systems	Area (Mha)	Nursery and Establishments	Rotation (Years)	Growth (MAI) (m ³ /ha/year)	Yield (Mm ³ /yr or m ³ /ha)	Assessment/ Note
Eucalypts	0.5	Coppicing, seedling at the spacing 1*1 to 3*3m	3-5 years	8-50 (on average at 25)		Pulpwood (80%)
Pines	0.7	No data	No data		No data	
Teak	0.9	Direct sowing, seed broadcasting, transplanting, stumps at the spacing 2*2 to 4*4m (1200-1600 stems/ha), thinning and pruning applied 3-4 times	15, 20-30, and possibly to 60 years	13.5		Clear-cut
Rubber	2.1	Mostly stump budding and seedling at the	24-30 years	26		Productivity is equal to Malaysia

		spacing at 3*7m (or ~420-520 trees/ha).		
Acacia	0.2	No data	No data	No data

Vietnam: The most common timber species are pines, acacias, and eucalypts, typically grown on short rotations and planted in a mixed stand (*e.g.*, acacias-eucalypts or other species). Species selection usually depends on site and climatic conditions, objectives of timber product, market conditions, and availability of seed, planting, and management technology. Generally low yields were found throughout the country (MAI at 8-10 m³/ha/year), with the notable exception of the southern region, where MAI's reached as high as 20-25 m³. The summary of IF silvicultural practices for the selected species in Viet Nam is presented (Table 11).

Table 11. The summary of IF silvicultural practices for the selected species in Viet Nam.

Species/ IF systems	Area (Mha)	Nursery and Establishments	Rotation (Years)	Growth (MAI) (m ³ /ha/year)	Yield (Mm ³ /yr or m ³ /ha)	Assessment/ Note
Eucalypts	0.5	Seedling, transplanting coppice cloning at the spacing 2*2m or 2.5*2.5m (mixing)	3-10 years	12	44 tonnes/ha	
Pines	0.3	No data	No data			No data
Teak	0.004	No data	No data			No data
Rubber	0.9	No data	No data			No data
Acacia	1.0	Seedling and transplanting at the spacing 3*3 or 2m (1,100-1,600 trees/ha) for pulpwood then thinning to 600-700 trees/ha; 3*3.5m (900 trees/ha) for saw logs and thinning to 100-200 trees/ha.	6-7 years for pulpwood, 15-20 years for saw logs	on average at 14	50 tonnes/ha	

III. Methods Development for Detecting, Mapping, & Monitoring Industrial Forests For Landsat Data (Task 4)

General statements

Sarawak and Sabah states in Malaysia were selected to develop and test the Landsat data-based IF detection methods including vegetation/forest fractional cover (*fC*) and vegetation indices (*VI*) datasets. Sarawak and Sabah were selected because (1) these two states show very impressive IF planting rates over the recent years, in particular in Sarawak where the IF area (not including rubber) has annually increased on average at 365% from 2000 to 2012; (2) these regions are very notorious for heavy cloud and hazy contamination so that it is very challenging for methods development; (3) the area is dominated by oil palm plantations which are not included in our targeted IF systems so that separating them is also very challenging in terms of methods development; (4) the IF data in Malaysia is quite firm compared to other selected countries and Malaysia has the most potential among five selected countries to invest and develop industrial forests, and it also plans to develop pulp and paper industries as one of its national priorities.

Sarawak covers 9 scenes including path 118 with rows 57, 58, & 59; path 119 with rows 57, 58, & 59; path 120 with rows 58 & 59; and path 121 with row 59. Likewise, Sabah covers 8 scenes consisting of path 116 with rows 56 & 57; path 117 with rows 55, 56, & 57; path 118 with rows 55, 56, & 57. The multi-temporal Landsat scenes used in this study are freely acquired from historical archives at the Eros Data Center over the past 15 years. Details regarding scenes selected were as follows: (1) the main scenes are selected for years 2000, 2003, 2006, 2009, 2012, and 2014, focusing on images from May to August of the years; (2) additional scenes used to fill the gaps of no-data in the selected scenes within ± 1 year (for example, the scenes in 1999 and 2001 can be used for filling the scene of 2000; however, more priority will be placed on the scenes of

2000 used to fill the gaps for the selected scene, closer to the original data is better, then the quality of the scenes used to fill the gaps in the selected scenes is the second priority); and (3) all errors or no-data of ETM + SLC off, clouds and cloud shadows must be removed and filled until 2.5% or to the acceptance level.

All scenes (a total of 563 scenes) used for this study will be pre-processed as follows: (1) the digital numbers (DNs) - radiance values at the sensor - exoatmospheric top-of-atmosphere reflectance values conversions; (2) atmospheric corrections to obtain surface reflectance values; (3) cloud, cloud shadow and waterbodies removals; (4) gap filling; and (5) dehazing. Then, these preprocessed scenes will be used for developing the methods. The general flowchart for developing the Landsat data-based IF detection methods begins with acquisition of Landsat data and ends with validation (Figure 24).

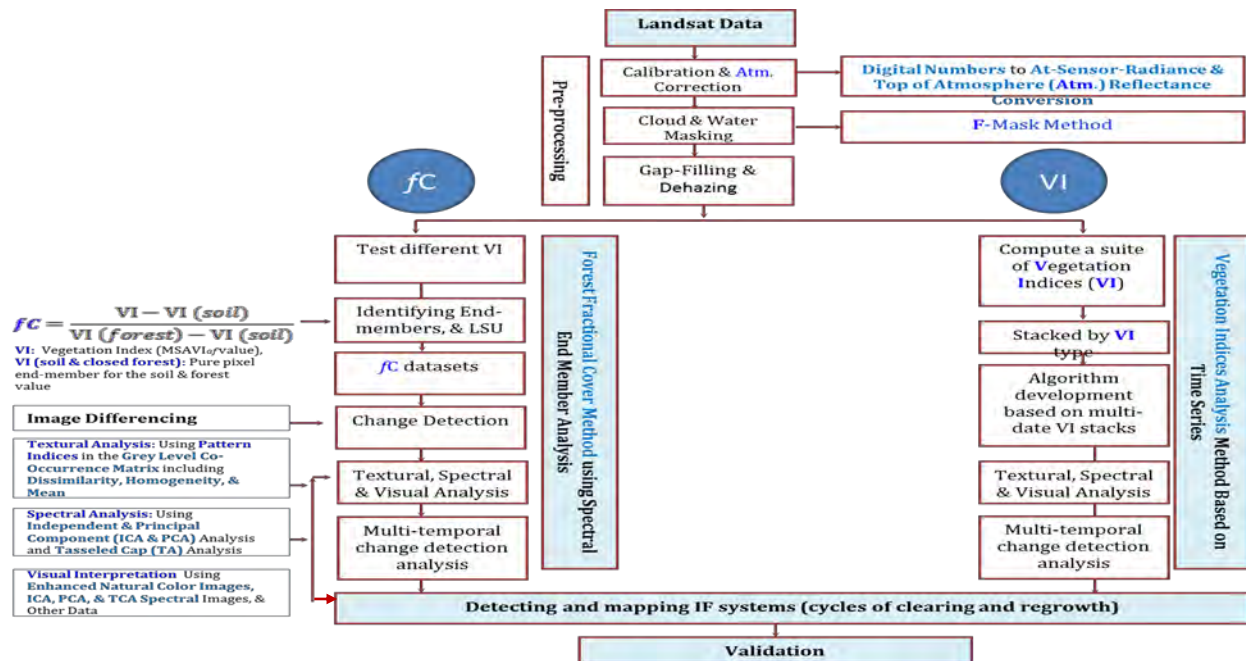

Figure 24. The general flowchart for developing the Landsat data-based IF detection methods.

a. Vegetation Indices/VI-based Industrial Forest Detection Method

The procedure for how to develop Landsat data-based IF detection method by using vegetation indices (VI) to transform preprocessed images into final IF maps is described (Figure 25). The main assumptions used for developing this method are:

- The cycle of increasing and reducing the VI values possibly indicates the cycle of clearing and regrowth of vegetation covers, typical for an IF/plantation stand.
- The time span for a cycle could indicate shorter (≤ 7 years) vs. longer (> 7 years) rotation IFs/plantations.
- The rate of increasing VI values (VI growth rate) may indicate for fast growing vs. slow growing timber plantation species.
- The spectral and textural characteristics of an IF stand may be different from other vegetation covers (*e.g.*, forests) and might differ among different IF species as well.

A suite of vegetation indices (VIs) will be computed in the preprocessed scenes: NDVI (Rouse *et al.*, 1974), SAVI (Huete, 1988), ARVI (Kaufman & Tanre, 1992), SARVI (Kaufman & Tanre, 1992), MSAVI2 (Qi *et al.*, 1994), and EVI (Huete *et al.*, 2002). However, for NDVI, the modified version of Karnieli *et al.* (2001), called $NDVI_{af}$, will be used by replacing the red band in the formula by the shortwave infrared band (SWIR) at 2.1 μm to reduce the atmospheric effects. Likewise, we will use the modified MSAVI ($MSAVI_{af}$) made by Matricardi *et al.* (2010) by replacing the red band in the original MSAVI by the shortwave infrared band (SWIR) at 2.1 μm .

These vegetation indices, calculated for the Landsat scenes, will be chronologically stacked by type (see, for example, stacking $MSAVI_{af}$ images in Sabah from 2000 to 2014 in Figure 26). This

provides an illustration of where the $MSAVI_{af}$ values have changed over time. Then, the changes of VI values from 2000 to 2014 are detected by using the image differencing method.

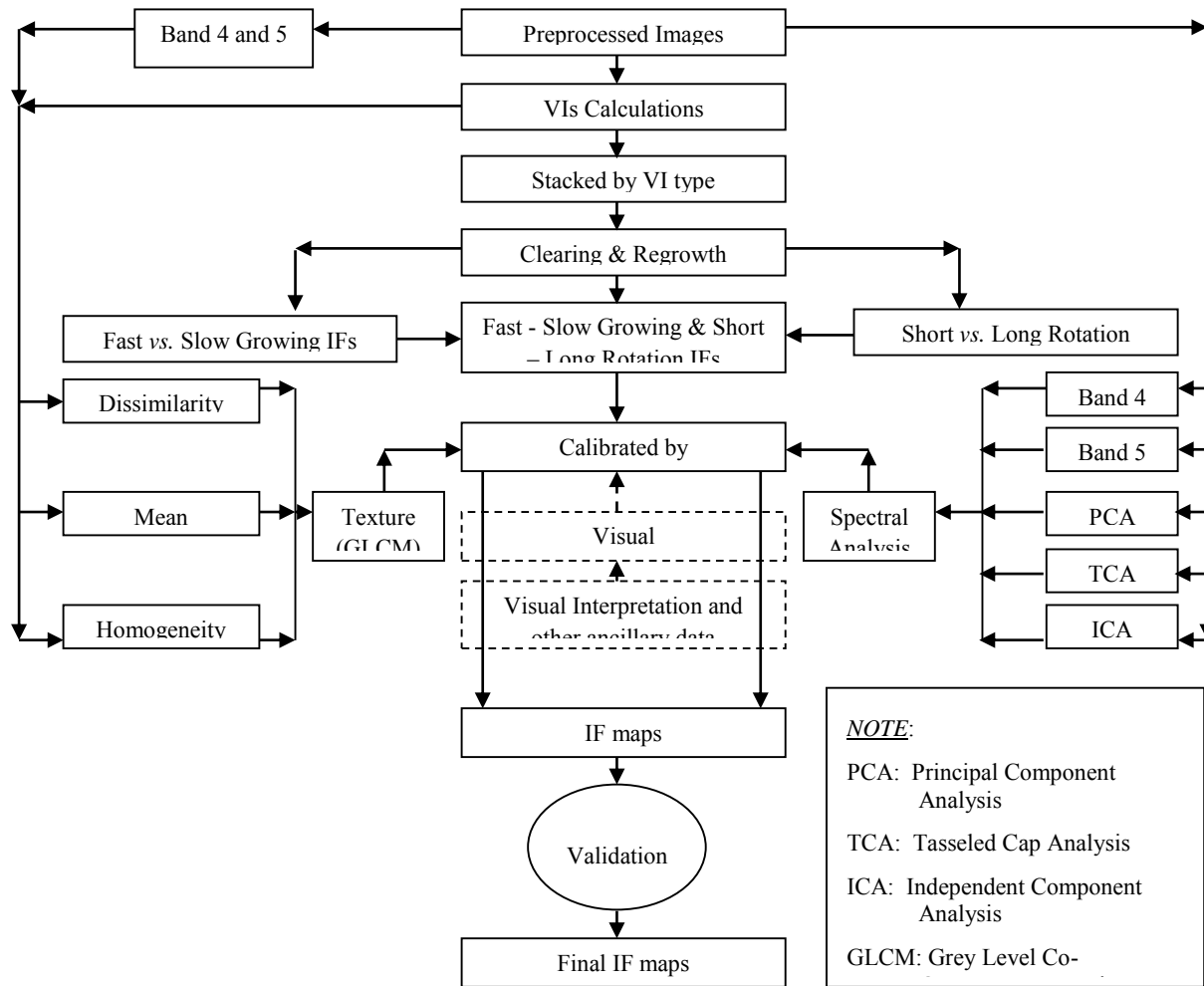

Figure 25. The flowchart of vegetation indices/VI-based IF detection method development.

This method is described as follows: $\Delta Change = VI(t_2) - VI(t_1)$ Where: VI is the value of vegetation index, t_2 : the after/later image and t_1 : the before/earlier image. A threshold chosen for identifying the change is ± 0.15 or $\pm 15\%$ based on the trial and error experiments. Figure 27 presents an example of how the VI value changes are detected at $\pm 15\%$. The red area shows a decrease of VI value at least -15% (clearing), and the yellow area shows an increase of the VI value at least +15% (regrowth).

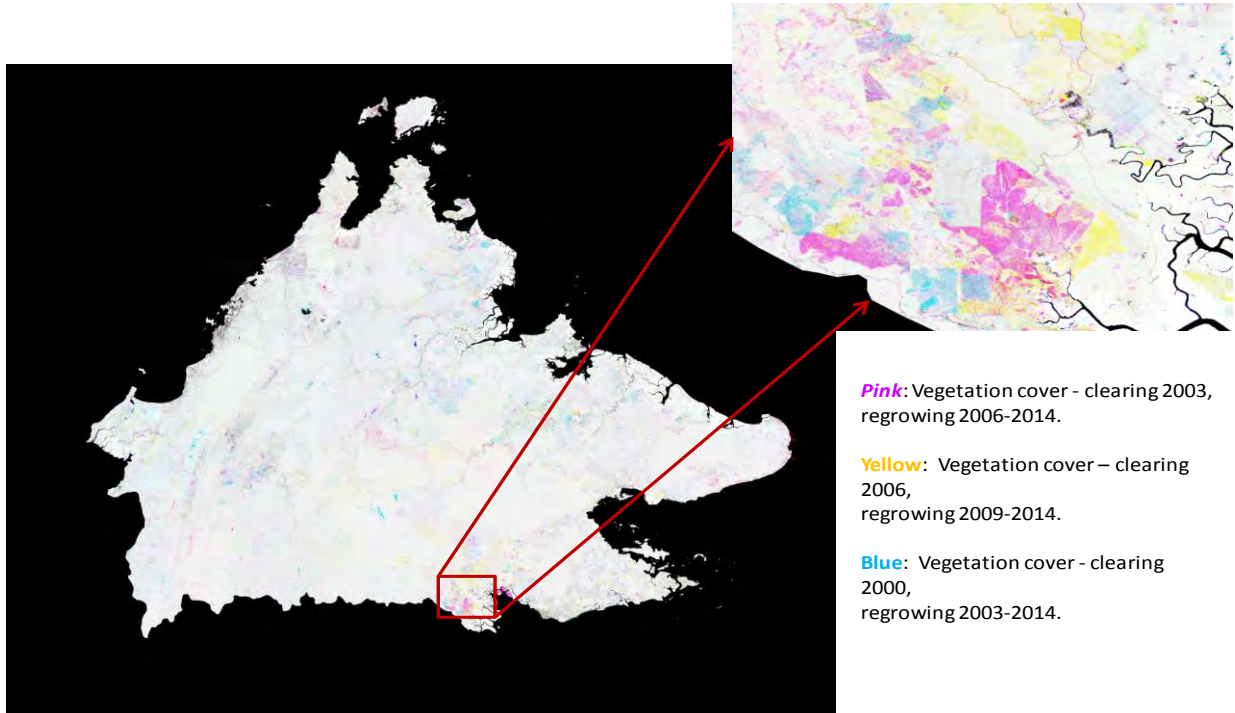

Figure 26. The MSAVI_{af} images stacked for Sabah from 2000 to 2014.

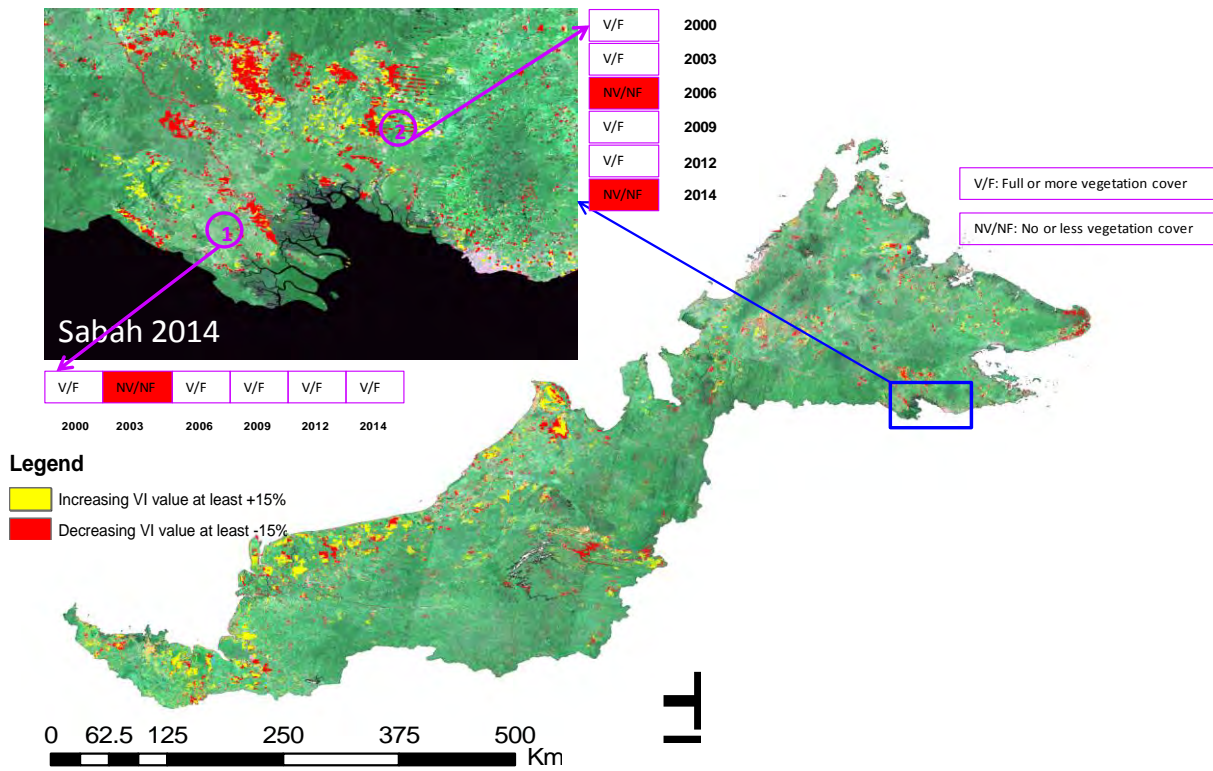

Figure 27. The VI value change detection at $\pm 15\%$ for Sabah and Sarawak, 2012-2014.

The VI value changes will be detected for years of 2000-2003, 2003-2006, 2006-2009, 2009-2012, and 2012-2014. By doing so, we will know the sequence of the VI value changes over time (e.g. in Figure 27, V/F indicates full or more vegetation cover (regrowth) and NV/NF presents none or less vegetation cover (clearing), and thus from V/F to NV/NF indicating a reduction in VI from full/more to less vegetation cover (clearing); and from NV/NF to V/F expressing an increase in VI from less to full/more vegetation cover (regrowth)). *The sequence or cycle of the change would provide initial clues for detecting industrial forests because it presents a cycle or a rotation which is typical for an industrial forest or timber plantation stand.* An example of how the changes of vegetation cover in Sarawak were detected and monitored based on the-

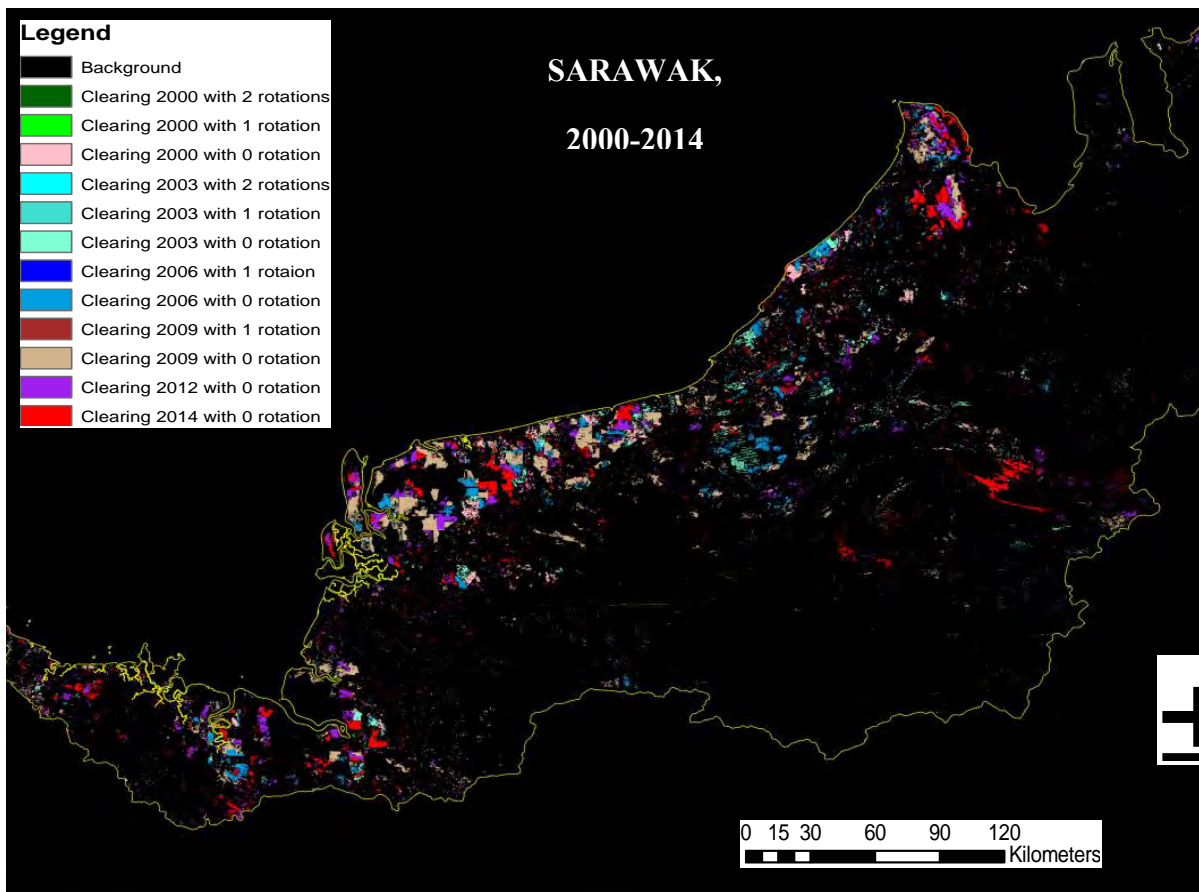

Figure 28. The cycles of clearing and regrowth of vegetation cover (rotation) based on the changes of MSAVI_{af} values in Sarawak from 2000 to 2014.

-changes of $MSAVI_{af}$ values. These changes indicate the cycles of clearing and regrowth (rotation) of vegetation cover equal to the increase and decrease of $MSAVI_{af}$ values from 2000 to 2014 in Sarawak is presented (Figure 28). In other words, *the sequence and time span of the VI changes could indicate shorter vs. longer rotation plantation stands*. That is, any changes of the VI value at or less than 7 years possibly indicates shorter rotation, and any changes of VI value more than 7 years could be longer rotation IFs (Figure 29).

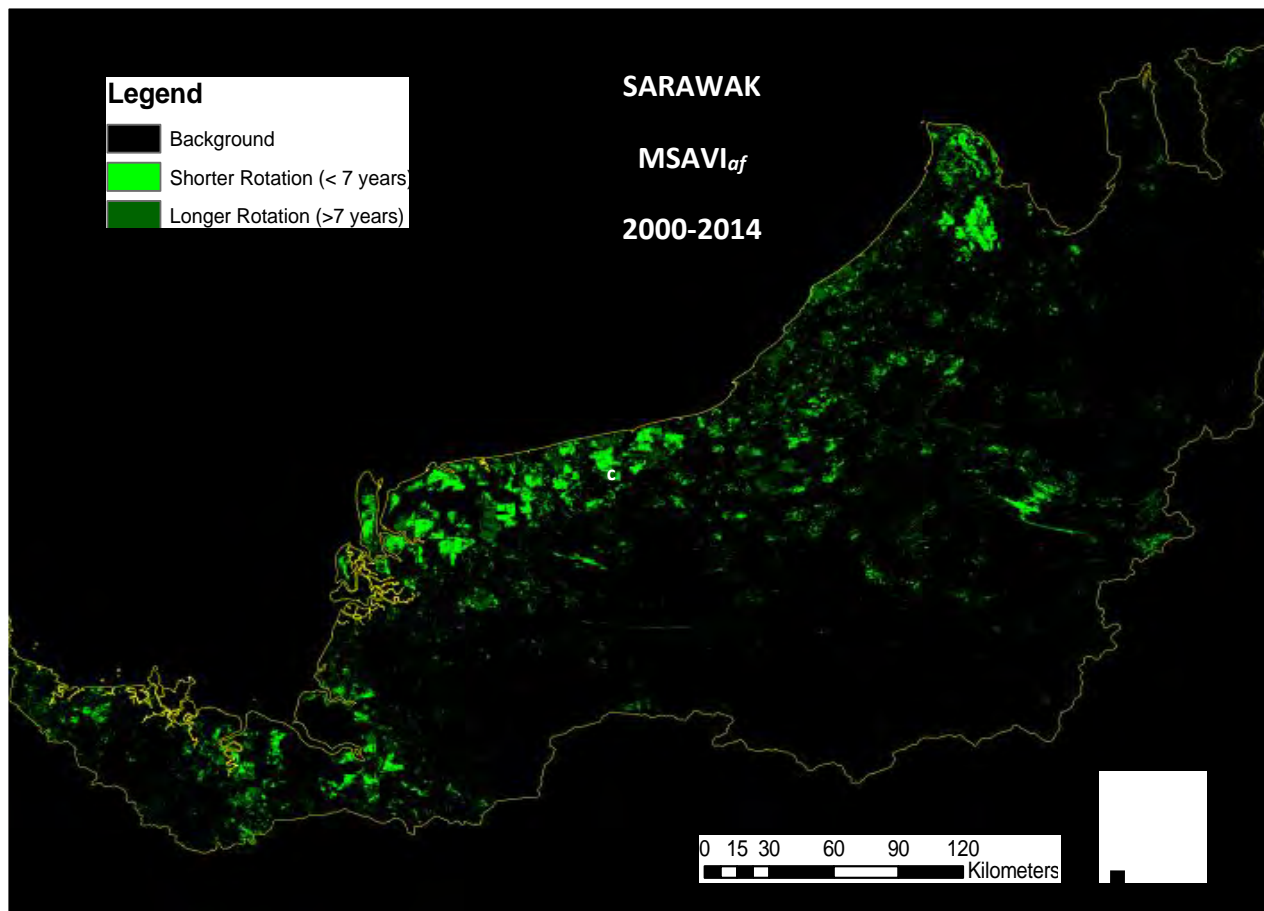

Figure 29. Possibly shorter & longer rotation plantations based on $MSAVI_{af}$ from 2000 to 2014 in Sarawak.

In addition to the time span of the VI changes which could indicate the rotation of an IF stand, *the growth rate of VI values could also indicate faster vs. slower growing stands*. This is because *the*

faster growing industrial forests or timber plantations could develop or grow their canopy/foliar faster than the slower growing industrial forests or timber plantations. The growth rate of the VI values is calculated as follows: $\Delta growth\ rate = (VI(t_2) - VI(t_1)) / VI(t_1)$. A number of experiments have been completed and the threshold of the VI value growth rate at 0.5 could indicate the faster and slower growing IF species. An example of detecting the possibly faster growing and slower growing plantations based on the growth rate of MSAVI_{af} values in Sarawak from 2000 to 2014 is presented (Figure 30).

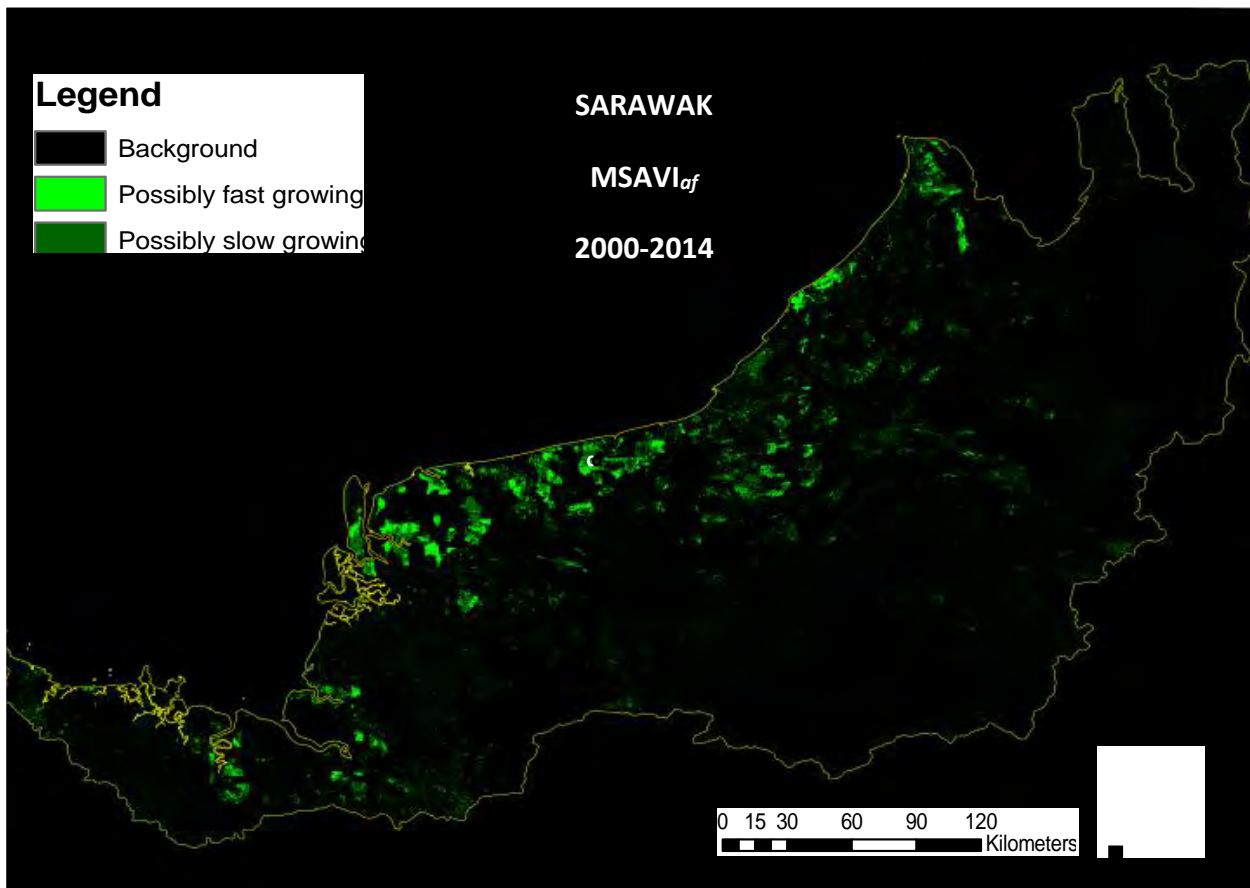

Figure 30. The possibly faster growing and slower growing plantations based on the growth rate of MSAVI_{af} values in Sarawak from 2000 to 2014.

By combining two products of possibly shorter vs. longer rotation and faster vs. slower growing plantation stands derived from VIs values changes, the fast-growing short-rotation and slow-

growing long-rotation IF stands could be detected. An example of possibly faster-growing shorter-rotation and slower-growing longer-rotation plantations is shown for Sarawak (Figure 31).

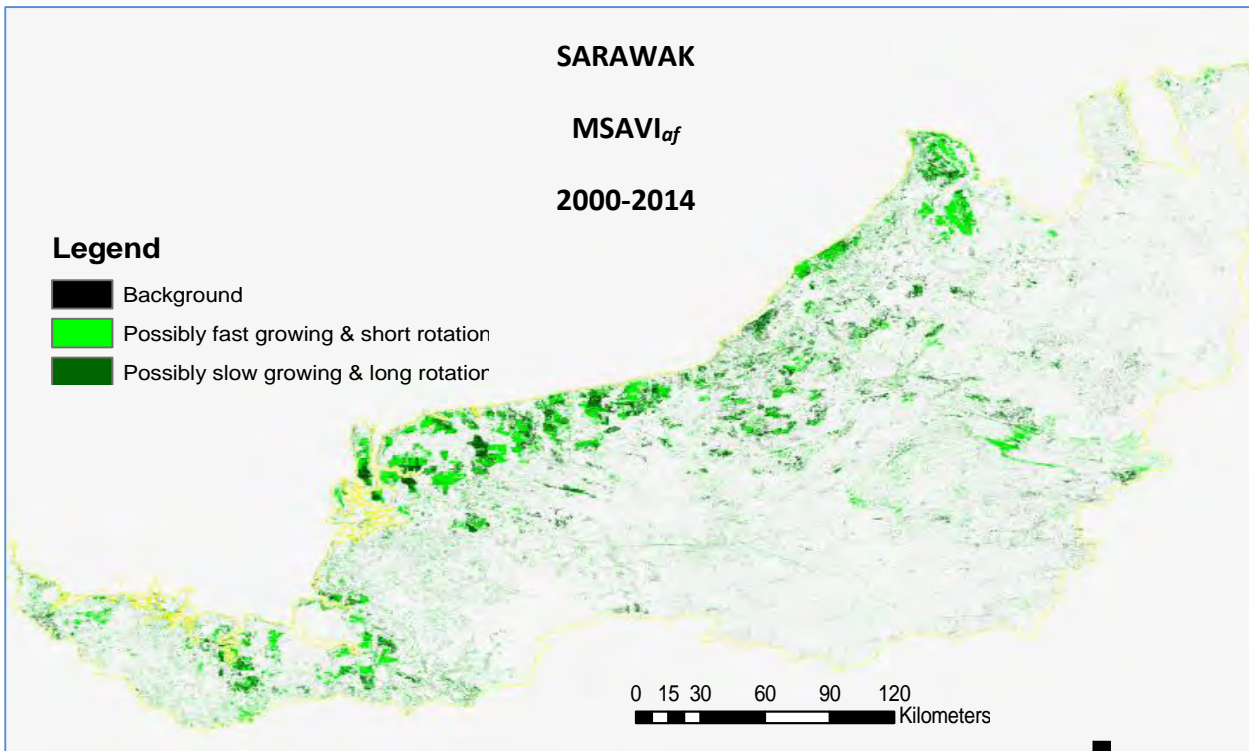

Figure 31. Possibly faster-growing, shorter-rotation and slower-growing, longer-rotation plantations in Sarawak from 2000 to 2014.

The above analysis has provided initial clues for detecting and mapping possibly faster-growing, shorter-rotation and slower-growing, longer-rotation plantations in Sarawak and Sabah. However, this evidence is not enough to know whether or not they are industrial forests or any specific vegetation covers. Therefore, further analyses are needed to detect and map them. The additional analyses to detect industrial forests and calibrate the final results will use textural analysis, spectral analysis, and visual interpretation. This task could be simplified by the fact that industrial forests are monoculture of one or a few of species. They are usually even-aged and have similar crown shape and regular spacing.

A number of textural analysis tests have been conducted on VI images, and band 4 and band 5 images for texture indices in The Grey Level Co-occurrence Matrix (GLCM) at different window sizes. I found that the following indices: Mean (MEA), Homogeneity (HOM), and Dissimilarity (DIS) worked well with the moving window size at 9*9 pixels. In addition to textural calculations for the VIs products, band 4 and 5 images are also used because they can separate different land covers (bare land, forest, and plantation) compared with other bands. An example of how the Mean index in GLCM calculated for a VI image is presented (Figure 32).

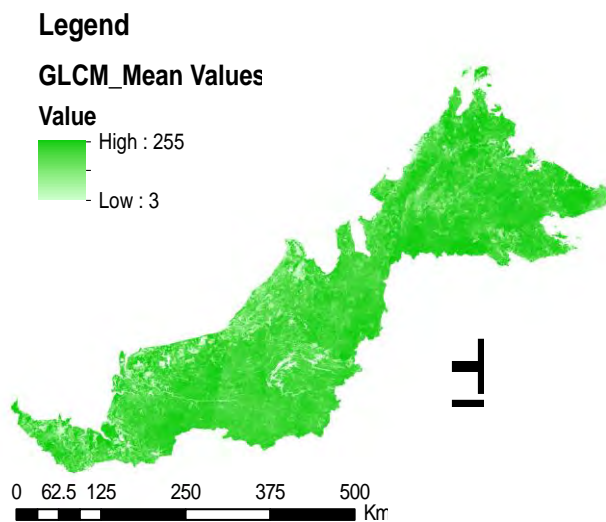

Figure 32. The Mean index in GLCM is calculated for a NDVI_{af} image in 2014.

Then, five land use and land cover types including *Acacia* plantations, natural forests, oil palm plantations, rubber plantations, and other timber plantations/IFs are selected to determine these texture indices values. The following figures (Figure 33) present the results of observing and determining the values of texture indices including Mean (MEA), Homogeneity (HOM), and Dissimilarity (DIS) for the NDVI_{af} images, band 4 and band 5 images from 2000 to 2014 in Sabah. These values will then be used to identify the focused IF systems (Figures 34 and 35).

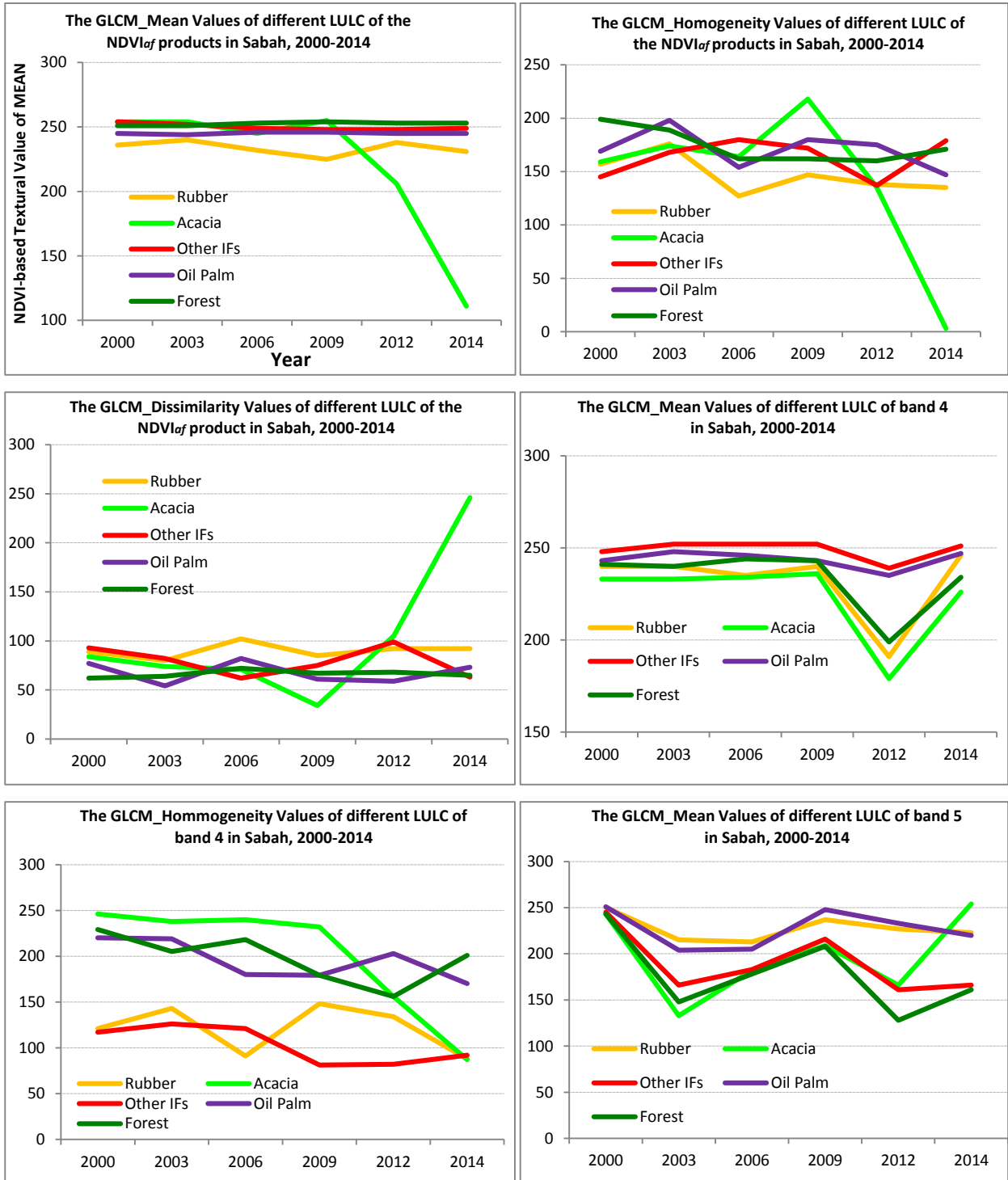

Figure 33. The values of GLCM_MEA, HOM, & DIS of different Land Uses/Land Covers in the NDVI_{af} product, band 4, & band 5 grey level images in Sabah, 2000-2014.

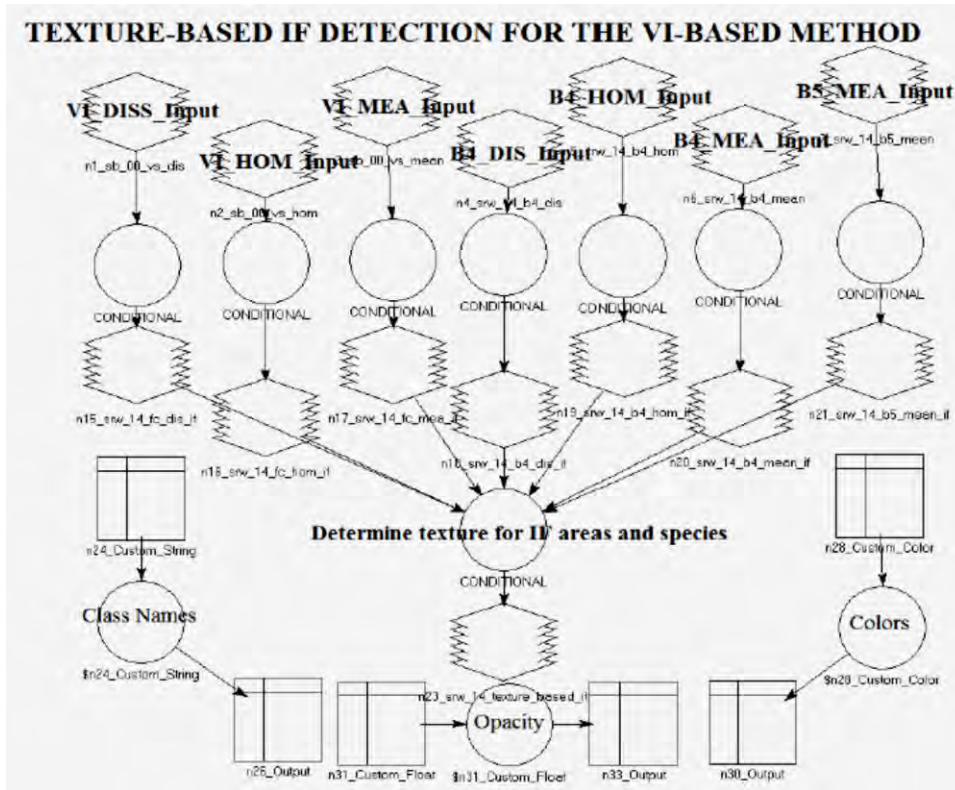

Figure 34. The texture-based models for the VI datasets to detect the focused IF systems.

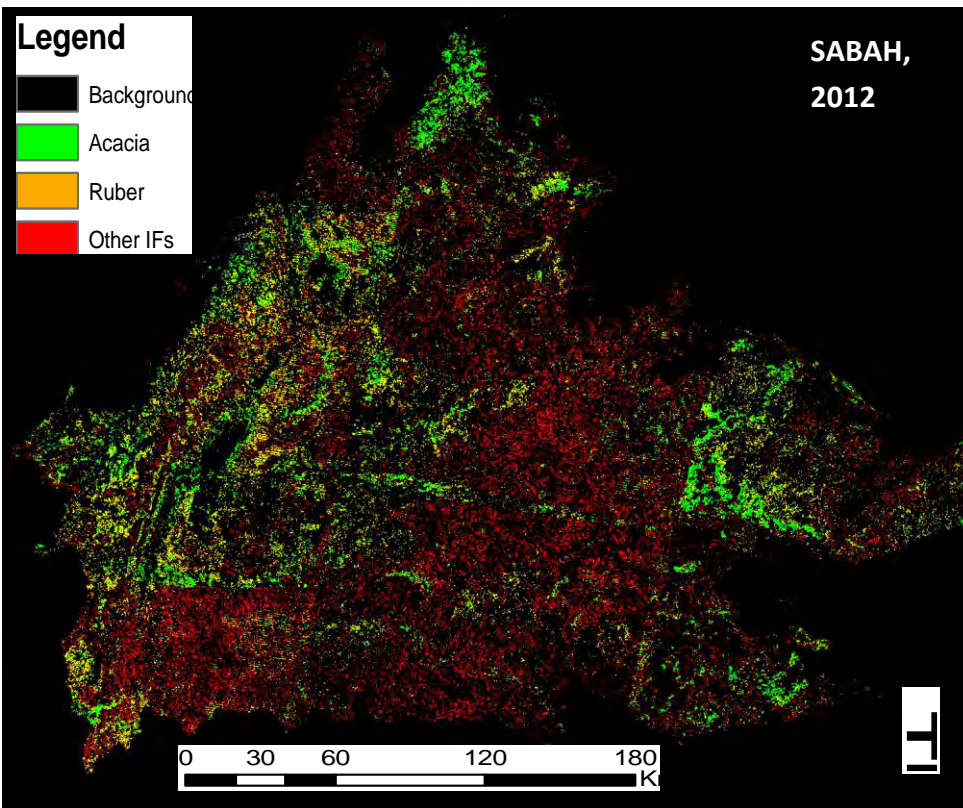

Figure 35. Detecting the targeted IF systems based on textural analysis in Sabah, 2012.

In addition to textural analysis, spectral analysis is also used as an added method to detect the focused IF systems. Principal Component Analysis (PCA), Independent Component Analysis (ICA), Tasseled Cap Analysis (TCA), and Band 4 and Band 5 are used in the spectral analysis. These analyses will be conducted on the preprocessed images by using the spectral analysis/transformation in the Erdas.

The results of applying PCA, ICA, and TCA to the preprocessed images in Sabah and Sarawak in 2000 are shown in [Figure 36](#) as an example. Then, likewise the textural analysis, the values of PCA, ICA, TCA as well as band 4 and band 5 for five different land use land cover (LULC) types are identified. The identification of these values is done by using the AOI (*area of interest*) function. Five these LULC types will be identified based on the ancillary data, visual keys, and verified by Google Earth check.

The results of identifying the values of PCA, ICA, TCA as well as band 4 and band 5 for five different LULC types (*Acacia* plantations, natural forests, oil palm plantations, *rubber* plantations, & other timber plantations/IFs) are shown in [Figure 37](#), [38](#), and [39](#). Based on these values, a model has been developed to detect and map the expected IF systems ([Figure 40](#)). Its result is presented in [Figure 41](#) as an example for detecting the IFs based on spectral analysis in Sabah, 2014.

Lastly, to calibrate the vegetation indices-based IF detection maps, visual interpretation will be used. This interpretation is done based on interpretation keys in spectral images, VIs-derived products, and preprocessed images by using the experience and knowledge of interpreter. At the same time, other data sources will be also used to support and verify the visual interpretation process. [Figure 42](#) shows an example of interpreting IFs.

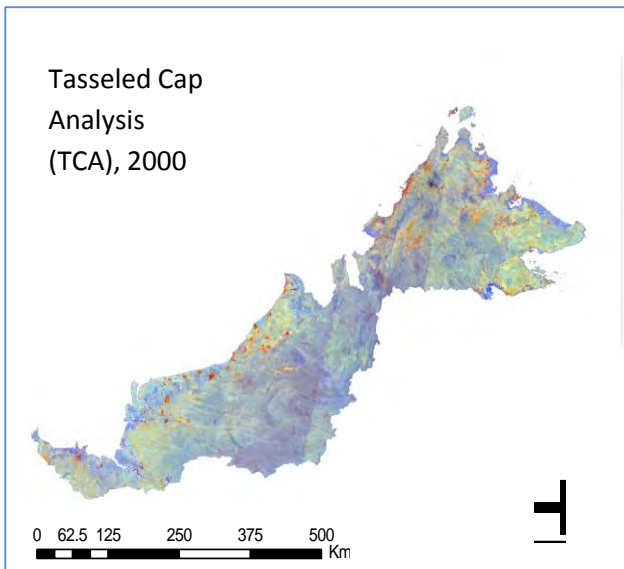
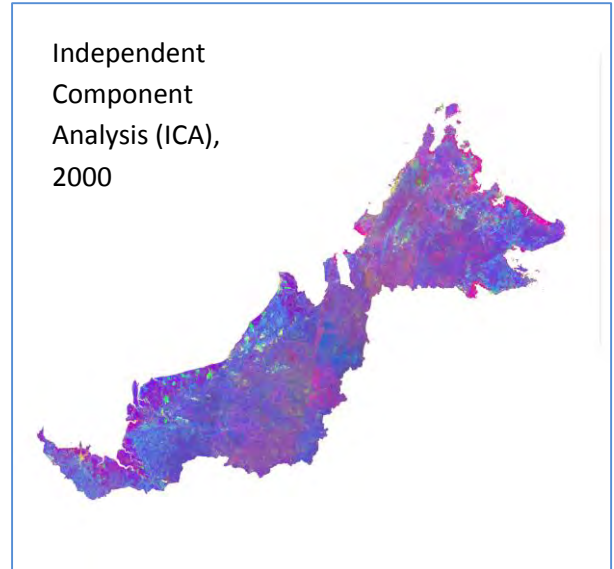
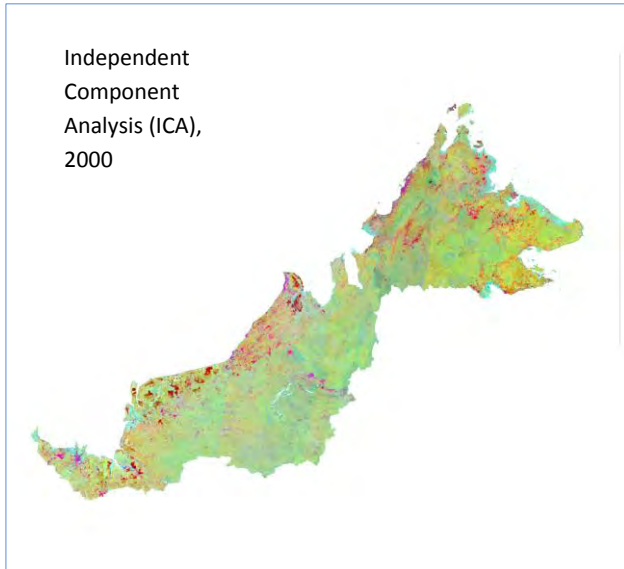

Figure 36. Spectral analysis/transformation results (PCA, ICA, & TCA) for Sabah and Sarawak in 2000.



Figure 37. The Principal and Independent Components values for acacias, natural forests, oil palms, rubbers, and other industrial forests of layers 1, 2, & 3 in Sabah, 2000-2014.



Figure 38. The Tasseled Cap values for acacias, natural forests, oil palms, rubbers, and other industrial forests of layers 1, 2, 3, 4, 5, & 6 in Sabah, 2000-2014.

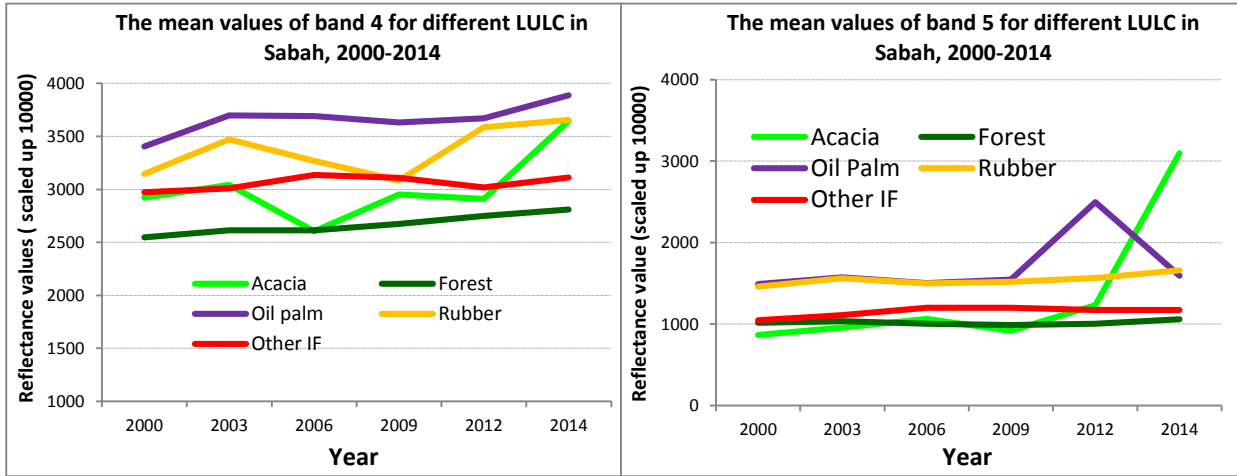

Figure 39. The mean values of band 4 and band 5 for the different land use/land cover areas of interest in Sabah, 2000-2014.

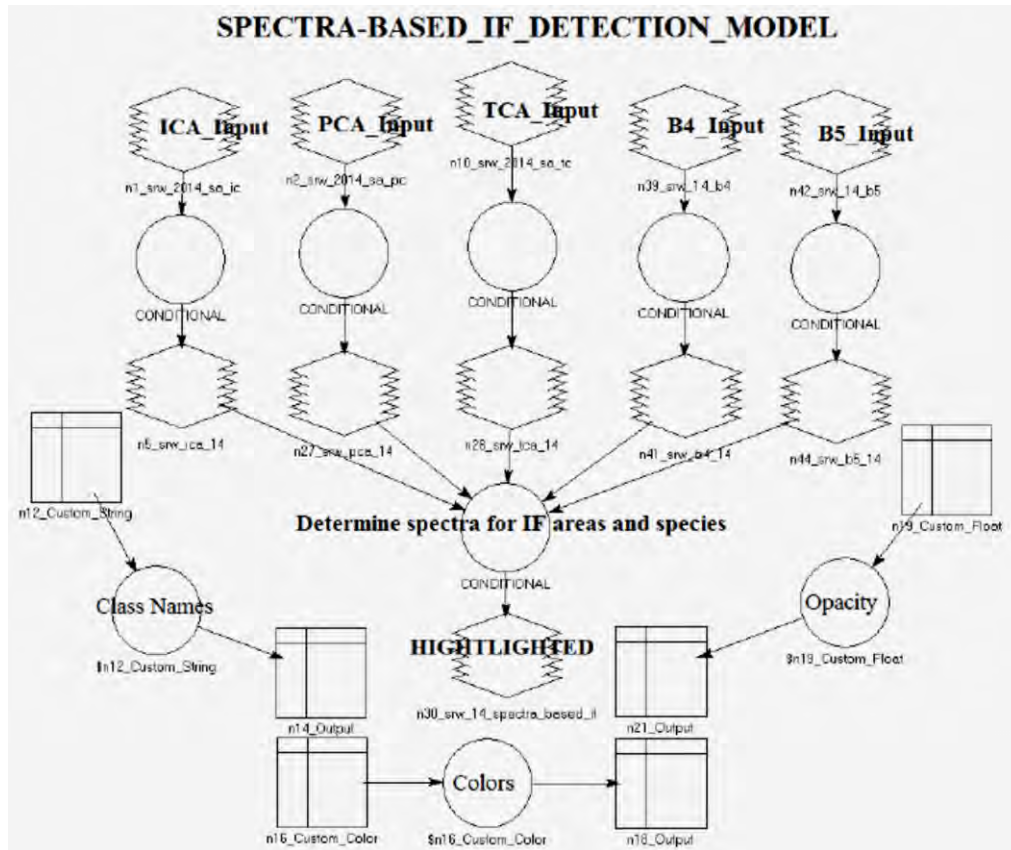

Figure 40. The spectra-based models for the VI datasets to detect the focused IF systems.

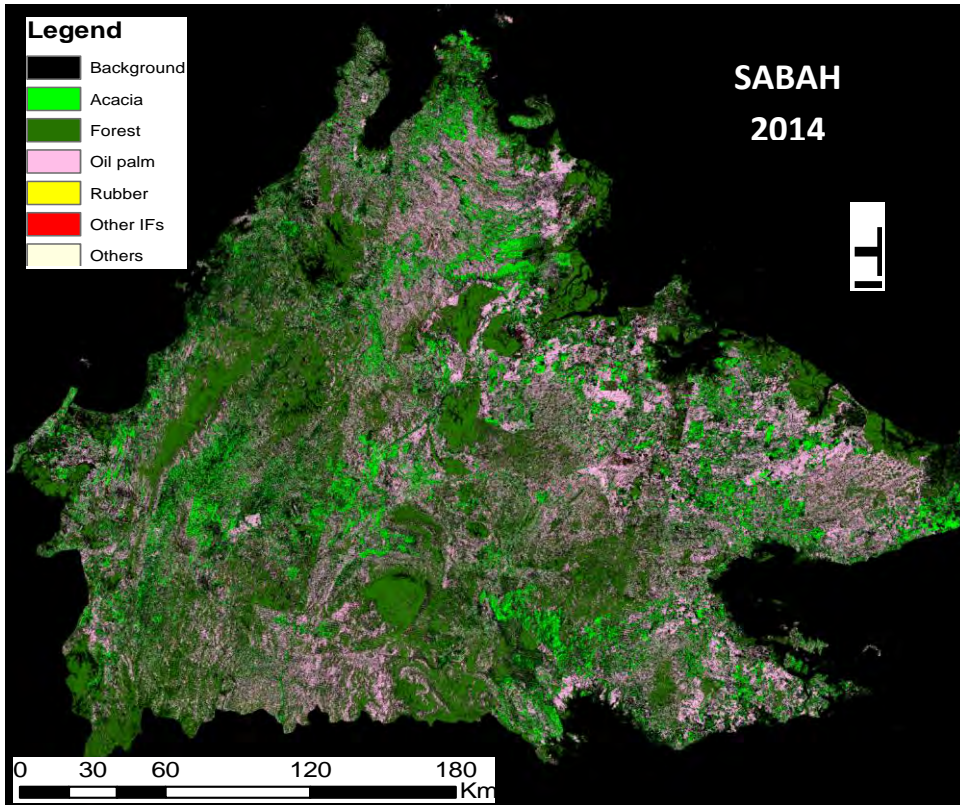

Figure 41.
Detecting the
IFs based on
spectral
analysis in
Sabah, 2014.

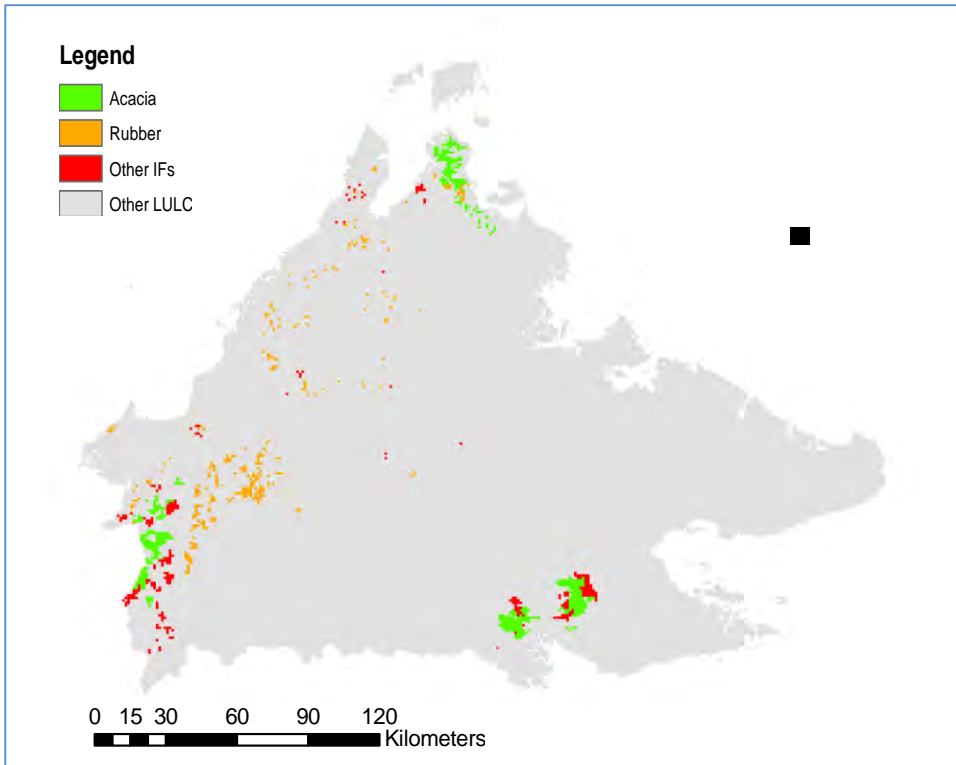

Figure 42.
Visual
interpretation-
based IF map in
Sabah, 2000.

After obtaining the data based on fast-growing short rotation & slow-growing long rotation IFs, textural analysis, spectral analysis, and visual interpretation, the IF maps will be made by doing their combinations based on rules/conditions as presented in [Figure 43](#).

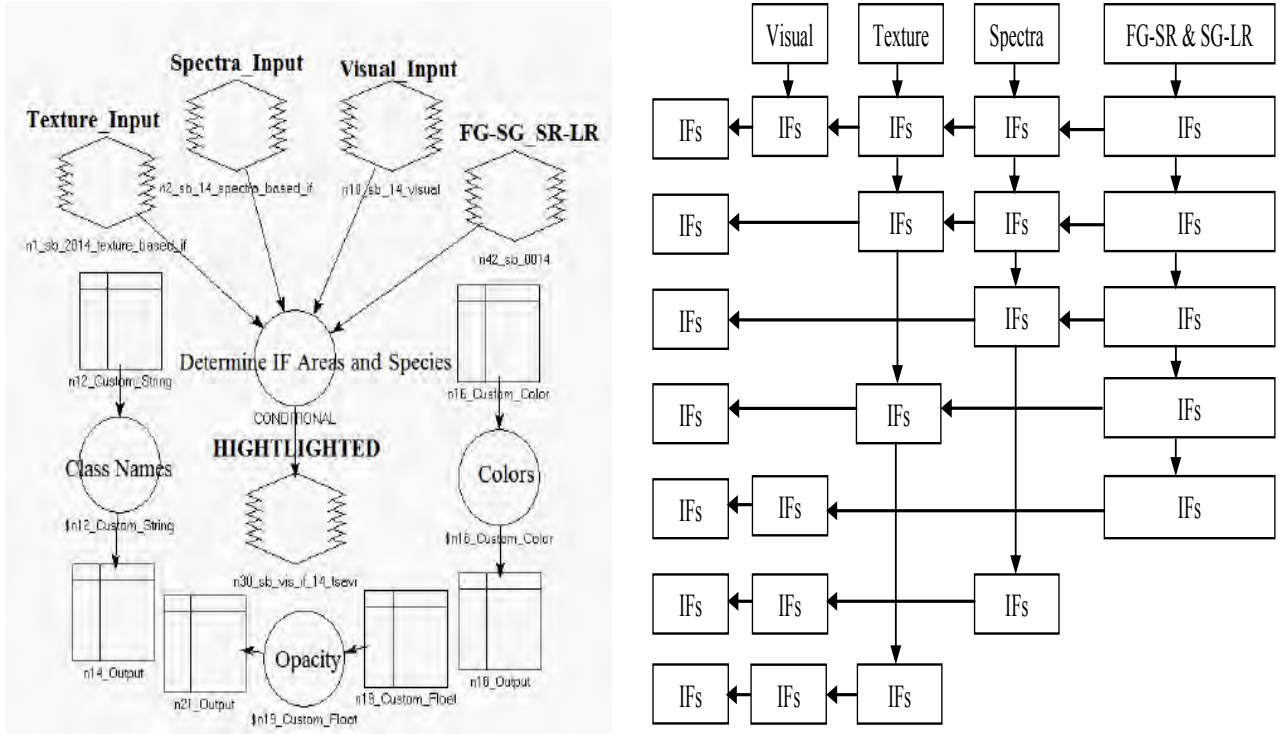
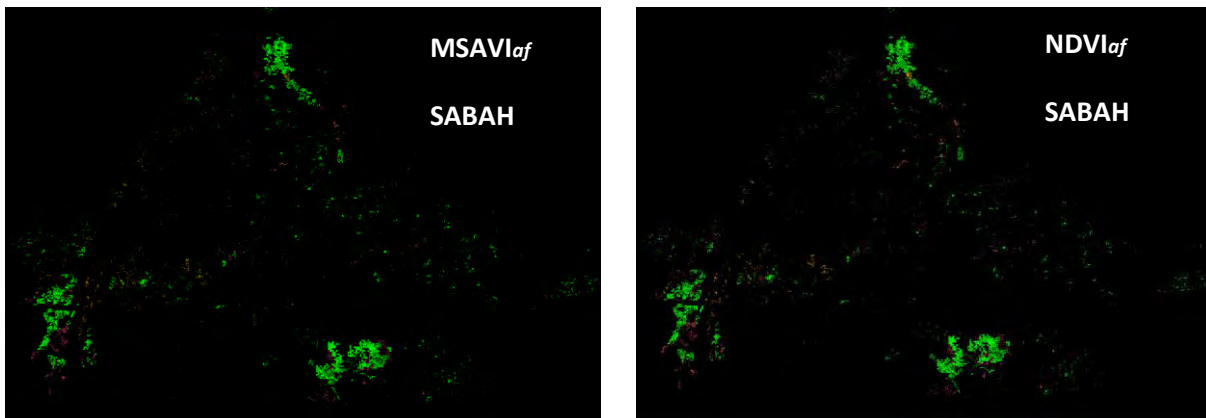

Figure 43. General IF detection model based on the combinations of different datasets.

In the other word, the combinations are interpreted as follows:

$$f(IF_s) = \sum([Texture(IF_s) \cap Spectra(IF_s) \cap FGSR-SGLR(IF_s) \cap Visual(IF_s)] + [FGSR-SGLR(IF_s) \cap (Texture(IF_s) \text{ OR/AND } Spectra(IF_s) \text{ OR/AND } Visual(IF_s))] + [Visual(IF_s) \cap (Texture(IF_s) \text{ OR } Spectra(IF_s))])$$

Figure 44 shows the IF maps in Sabah in 2014 based on different VIs as an example.



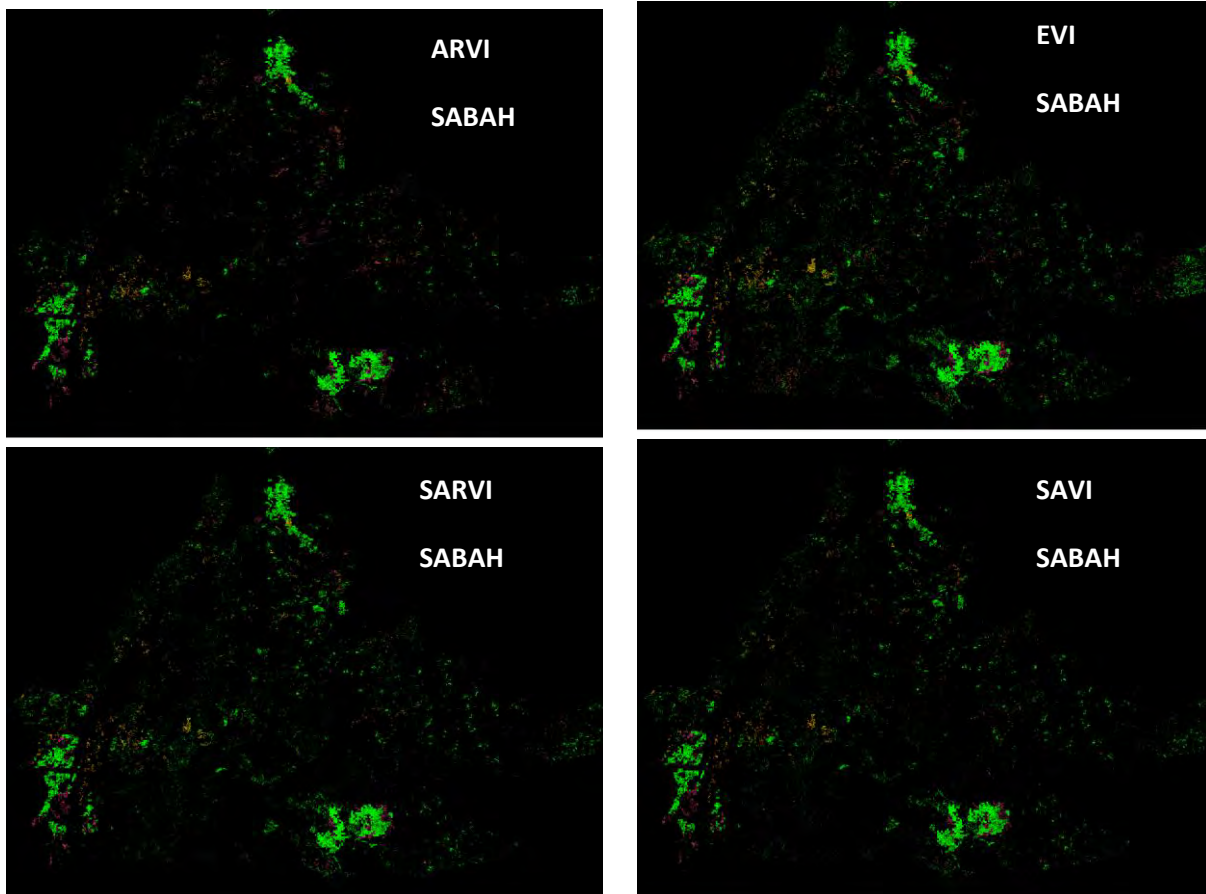

Figure 44. The different VIs-based IF detection maps in Sabah, 2014.

b. Fractional Cover/ fC -based Industrial Forest Detection Method

In general, the approach for this method is similar to the above vegetation indices/VI-based industrial forest detection method. However, it is developed based on the changes of fractional vegetation covers or the cycles of clearing and regrowth of vegetation covers instead of the VI value changes. In other words, it further examines the planting and harvesting cycles of a tree plantation, which are typical for an industrial forest stand, based on how its fractional cover is changed over time. This method is built based on the following assumptions:

- The cycle of increasing and reducing the vegetation coverage fraction (fC) and vice versa possibly indicates the cycle of clearing and regrowth or the harvesting and planting cycle which is typical for an IF stand.

- The time span for the planting and harvesting cycle of a tree plantation could indicate the short *vs.* long rotation.
- The rate of increasing the coverage (*fC* value growth rate) of an industrial forest stand may indicate for fast growing *vs.* slow growing species.
- The different vegetation cover types in general and industrial forests in particular can get the *same coverage* (or the same *fC* value) but their *biomass contents* and *leaf area index* may be *different* (*e.g.*, closed forests *vs.* timber plantation *vs.* oil palm *vs.* agricultural land).
- The different vegetation covers may have different texture and spectra.

This method will use the same preprocessed dataset as the above VI-based IF detection method. A test was done for vegetation indices including ARVI, EVI, MSAVI_{af}, NDVI_{af}, SARVI and SAVI to see which index works the best for further *fC* analysis. The result of this test shows that the MSAVI_{af} worked the best. Thus, this MSAVI_{af} index will be used for producing vegetation cover datasets, and applying the method (Figure 45).

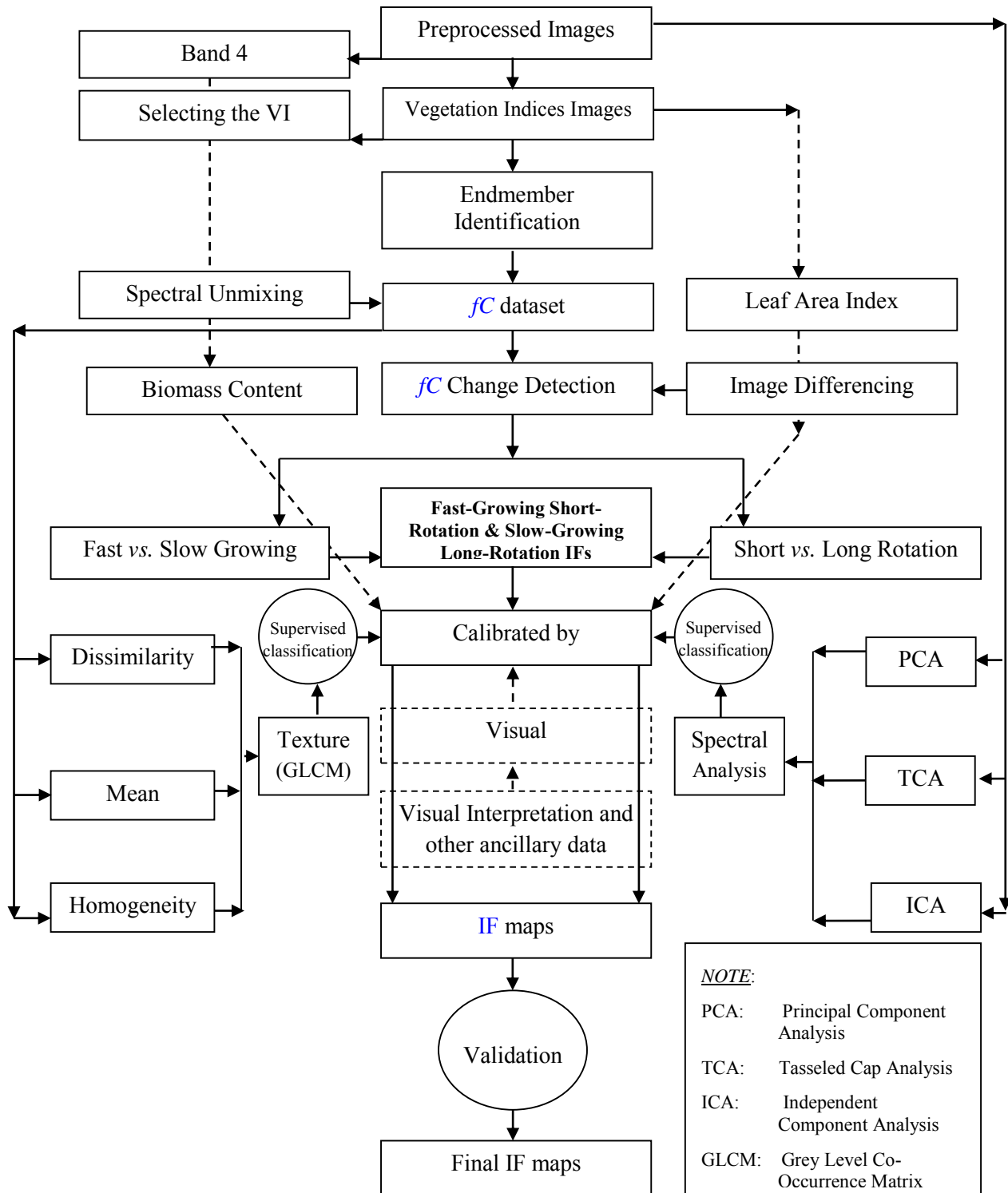

Figure 45. The flowchart of the *fC*-based IF detection method development.

From the $MSAVI_{af}$ products, two spectral end-members are created: bare soil/land and closed canopy forest (Figure 46 based on image examinations using the AOI (area of interest) tool.

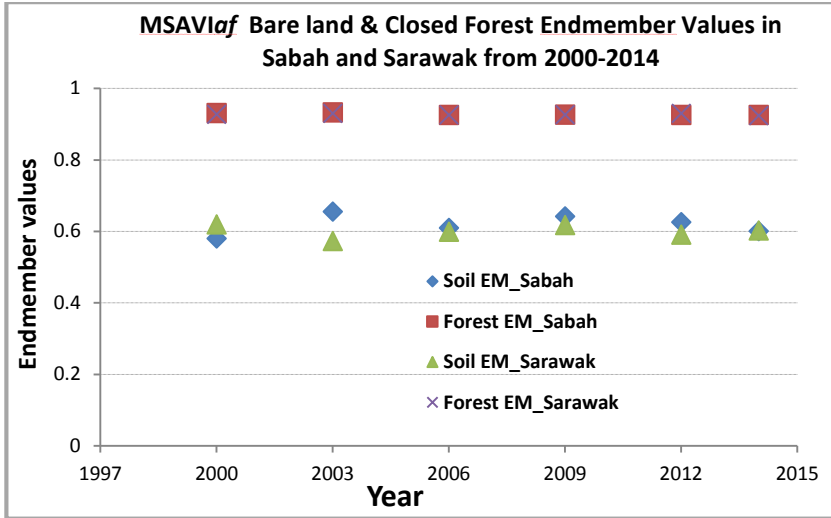

Figure 46. The endmember values of closed forests and bare soils/lands for MSAVI_{af} products in Sarawak and Sabah, 2000-2014.

Then, these two spectral endmembers are used to “un-mix” each pixel into a ratio of the two components in the linear spectral un-mixing model.

$$fC = \frac{VI - VI (soil)}{VI (forest) - VI (soil)}$$

This results in producing forest/vegetation fraction cover datasets that are vegetation continuous fields ranging from 0 to 100% coverage of vegetation for Sabah and Sarawak from 2000 to 2014 (Figure 47).

As illustrated in the above method, changes of vegetation cover in the study area will be detected and analyzed using the image differencing method. A threshold chosen for identifying the change is also ± 0.15 (or $\pm 15\%$) based on the trial and error experiments. The fC change detection result is presented for Sabah and Sarwak (Figure 48) as an example. The harvesting and planting cycle or the rotation of an IF stand will indicate an increase and decline of the fC value or the vegetation coverage fraction (fC).

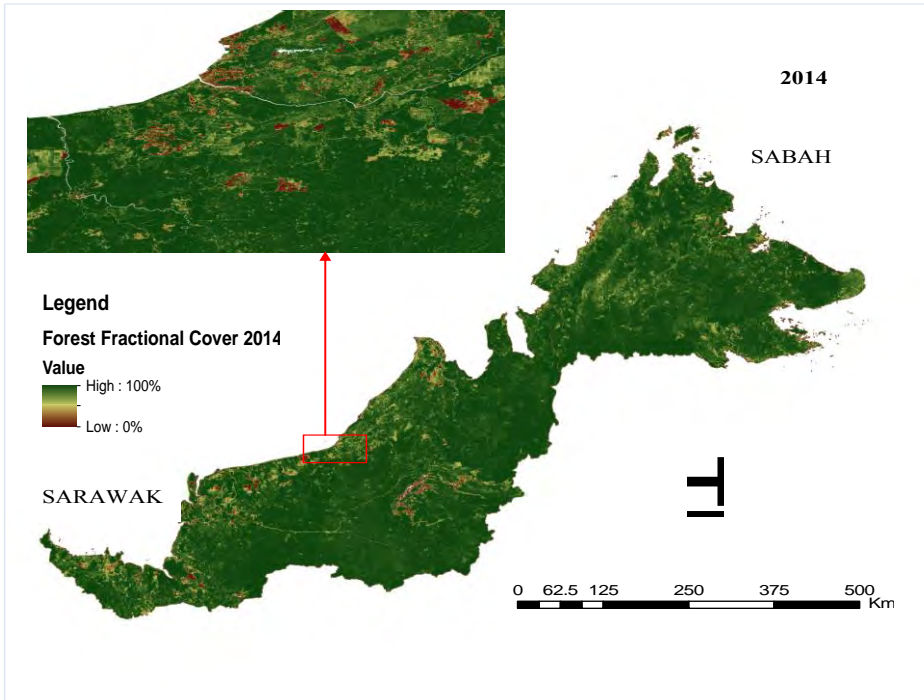

Figure 47. The forest/vegetation fractional covers (*fC*) produced from the MSAVI_{af} products in 2014 for Sarawak and Sabah.

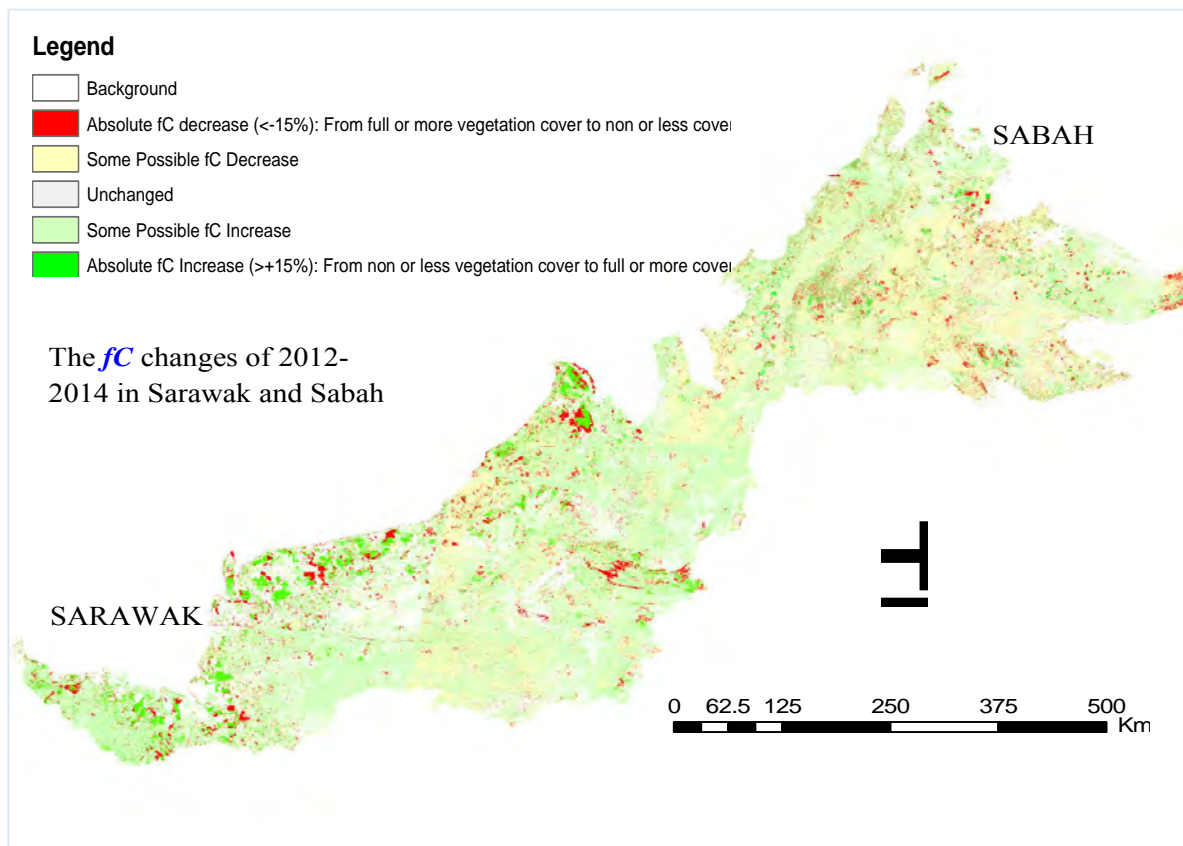

Figure 48. The *fC* changes detection for 2012-2014 in Sarawak and Sabah.

The results of monitoring the increasing and declining of fC values over time in the study area possibly show the time span for a silvicultural cycle, and this could indicate the rotation of clearing and regrowth or the planting and harvesting of tree plantations. Like the above methods, the cycle of 7 years is used to classify the shorter vs. longer rotation plantations. The result of identifying possible shorter and longer rotation plantations is illustrated for Sabah and Sarawak, from 2000 to 2014 (Figure 49).

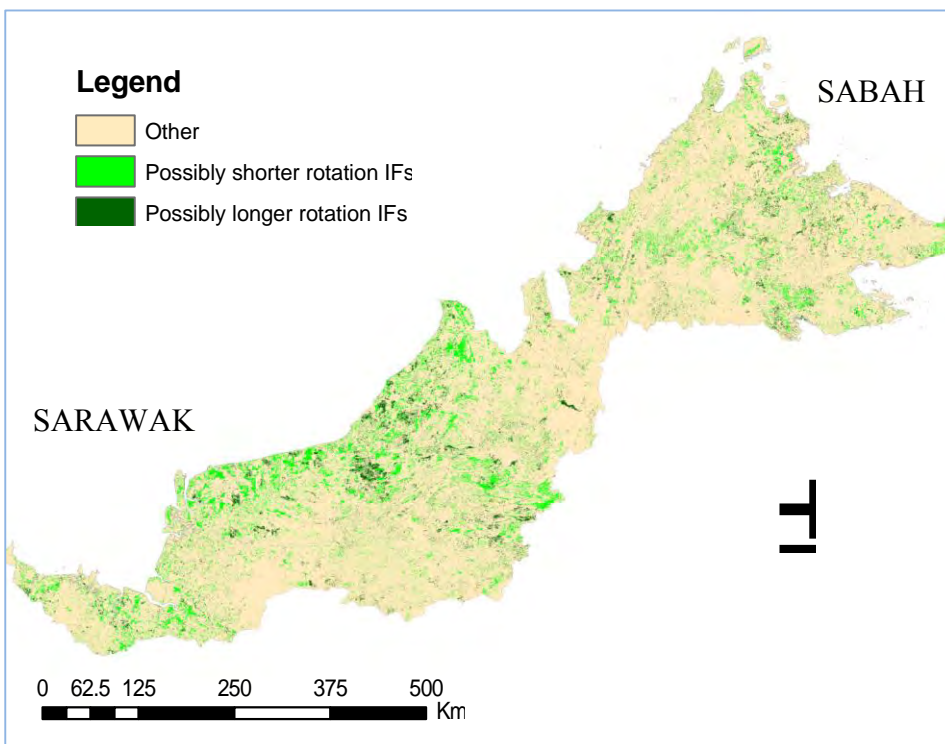

Figure 49. The possibly shorter & longer rotation IFs based on fC datasets in Sabah and Sarawak.

The next analysis for the growth rate of the fC values will provide an important clue for detecting industrial forests because the growth rate of the vegetation covers (fC values) may indicate the faster-growing and slower-growing plantations. The growth rate of the vegetation fractional cover (fC values) is calculated as follows: $\Delta growth\ rate = (fC(t2) - fC(t1)) / fC(t1)$. The value 0.5 is also selected as a threshold to indicate faster-growing vs. slower-growing. The preliminary result of this analysis step is presented for Sabah and Sarawak (Figure 50). Then, these

two datasets will be combined to create a shorter-rotation faster-growing and longer-rotation slower-growing industrial forest dataset (Figure 51).

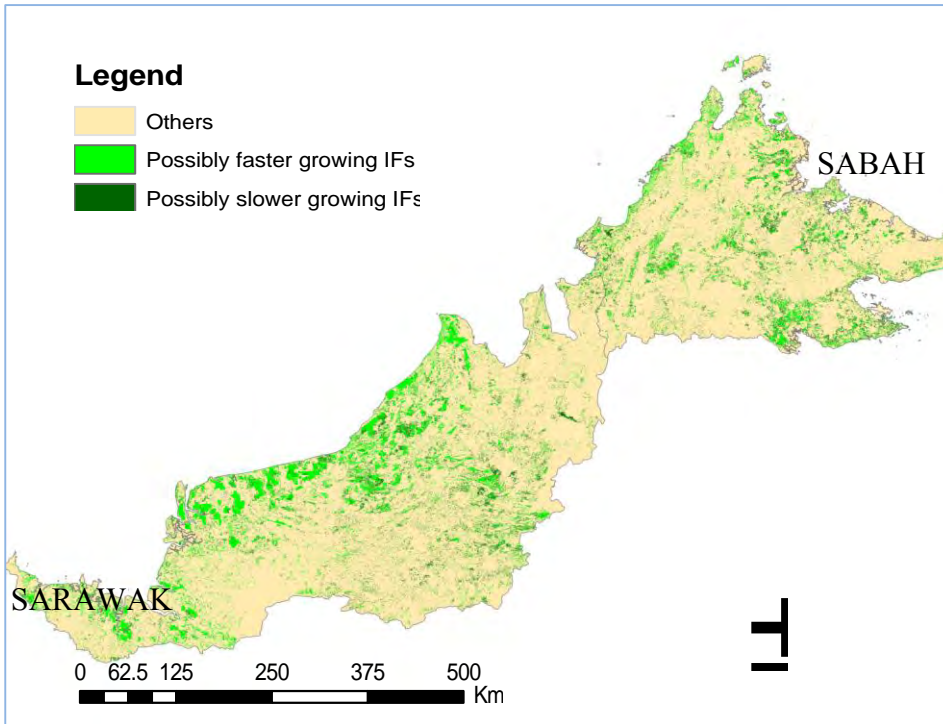

Figure 50. The possibly faster growing and slower growing industrial forests based on *fC* datasets in Sabah and Sarawak.

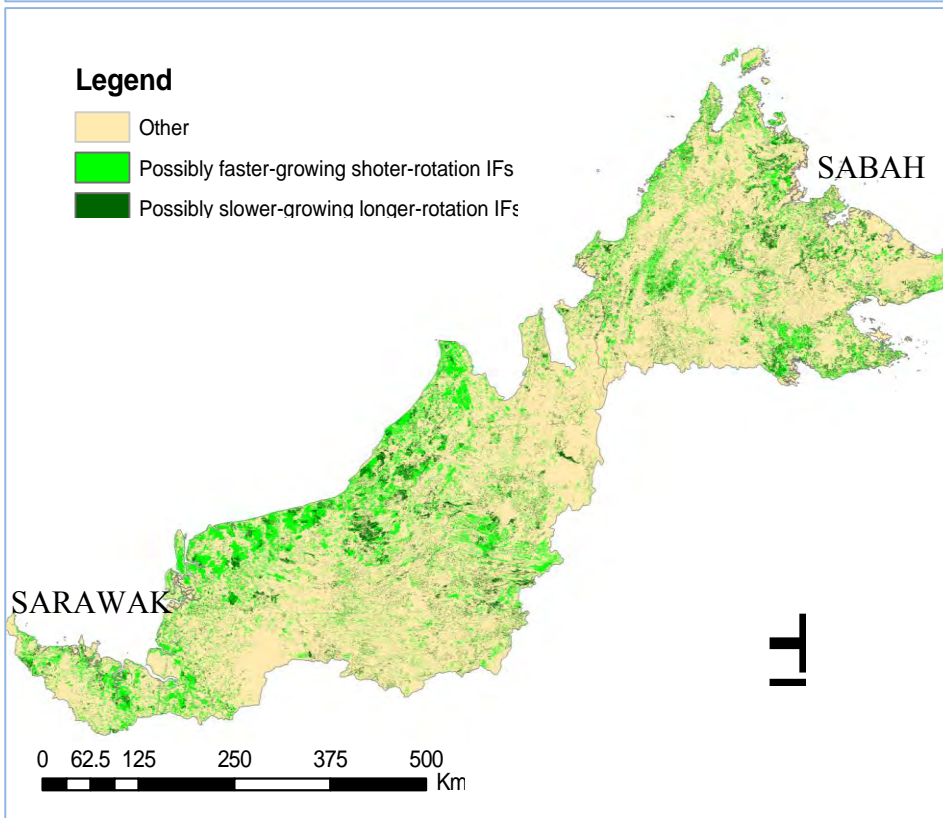

Figure 51. The possibly shorter-rotation faster-growing and longer-rotation slower-growing industrial forests based on *fC* datasets in Sabah and Sarawak.

Another important assumption used to develop the fC -based IF detection method is that the different vegetation cover types (*e.g.*, closed forests *vs.* timber plantation *vs.* oil palm *vs.* agricultural land) in general and industrial forests (*e.g.*, acacias *vs.* rubbers *vs.* teaks) in particular can get the same coverage (or the same fC value) but their biomass contents may be different. The band 4 value will be used to study this biomass content for different vegetations (Figure 52). To further examine this assumption, a statistical test was conducted by using non-parametric two-related-samples test (Wilcoxon Signed Ranks Test) for 30 key locations in Sabah and another 30 locations in Sarawak from 2000 to 2014. Results indicated the same fC values and band 4 values are significantly different at $p < .0001$.

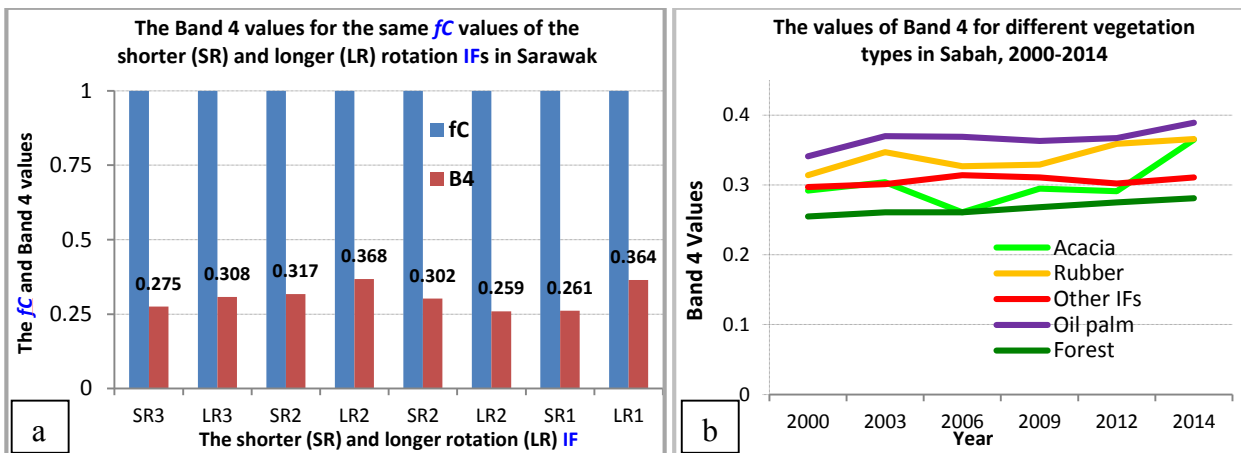

Figure 52. The band 4 values in the same vegetation cover in Sarawak (a), and the band 4 value for different vegetation types from 2000 to 2014 in Sabah.

In addition to the above assumption, a necessary assumption is also posed (*i.e.*, if the fractional covers (fC values) of different vegetation types are the same, their Leaf Area Index (LAI) may be different). In the other word, we examine whether the LAI among different industrial forest types in particular and vegetation types in general are different. Broge and Leblanc (2000) and

Haboudane *et al.* (2004) published studies using hyperspectral vegetation indices to predict green LAI. Similarly, we used the following predictive equation based on MSAVI to estimate LAI:

$$\text{LAI} = 0.1663 \exp(4.2731 * \text{MSAVI}) \quad \text{MSAVI} = 0.5 * [2 * \text{NIR} + 1 - \sqrt{(2 * \text{NIR} + 1)^2 - 8 * (\text{NIR} - \text{RED})}]$$

However, to be consistent with the VI datasets in this study, the MSAVI_{af} will be used to estimate LAI for different vegetation covers in the study area instead of using the original MSAVI in the above equations. The preliminary results of estimating LAI based on MSAVI_{af} in Sabah and Sarawak are presented (Figure 53).

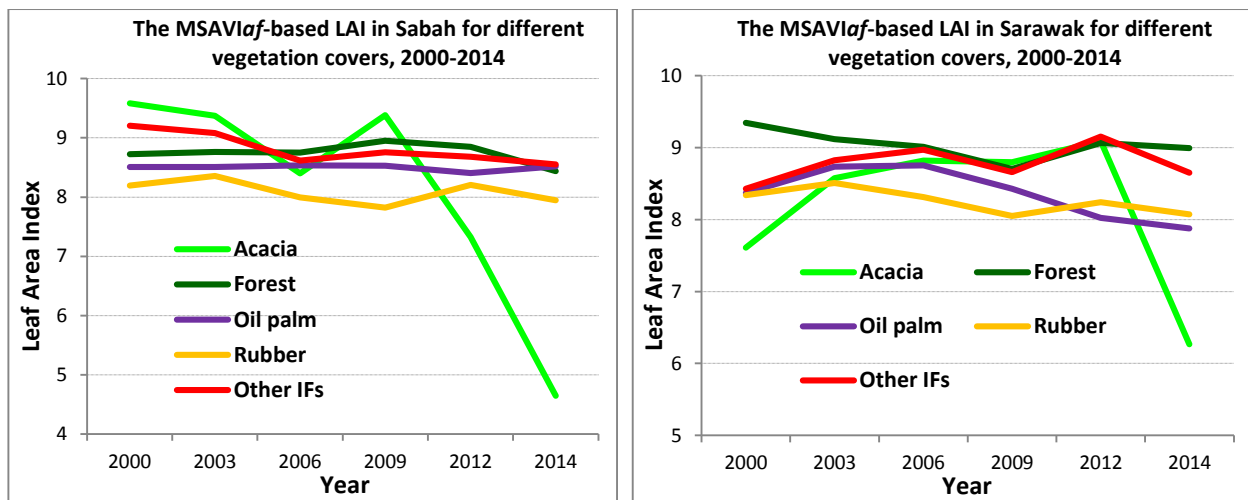

Figure 53. The MSAVI_{af} -based LAI for different vegetation cover types in Sabah and Sarawak, 2000-2014.

For fC -based IF detection method development, we will use spectral and textural analyses, along with biomass content and leaf area index analyses, as supporting methods to calibrate the results of detecting industrial forests based on multi-temporal forest fractional cover datasets analysis. However, the textural analysis will be only applied for fC datasets (unlike the VI-based method, which is applied for the VI products, and band 4 and band 5 images at the grey level).

Specifically, the textural analysis in the VIs-based method applies the Grey Level Co-occurrence Matrix (GLCM) for VIs image datasets including ARVI, EVI, MSAVI_{af}, NDVI_{af}, SARVI, and SAVI; band 4 and band 5 images. In the GLCM, the image textural indices consisting of Mean (MEA), Dissimilarity (DIS), and Homogeneity (HOM) are calculated and applied for the vegetation indices images (VI products) and band 4 image datasets, while band 5 grey level images are only applied and calculated for the index Mean (MEA). However, in this *fC* method, the indices will be applied for the *fC* datasets only. Then, they will be classified based on the supervised approaches (not using AOI to identify the values and then building models to detect the expected LULC types based on the identified values as the VI-based method above). An example of applying textural analysis is presented for the *fC* dataset of the year 2000 in Sabah and Sarawak (Figure 54).

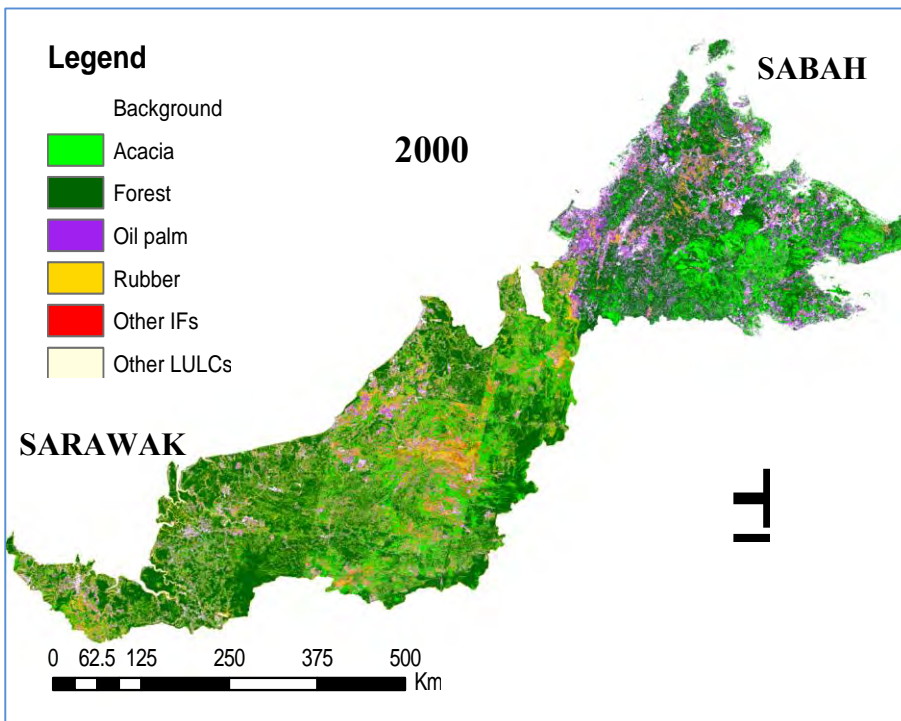

Figure 54. The textural analysis-based land use/land cover map for the *fC* dataset in Sabah and Sarawak in 2000.

This *fC*-based method will also use the spectral analysis consisting of Principal Component Analysis (PCA), Independent Component Analysis (ICA), and Tasseled Cap Analysis (TCA). The

datasets used for the spectral analysis in this method is the same to the dataset used for the VIs-based IF detection method. However, there is only one difference; instead of manually identifying the typical values for the expected IFs or other land uses/land covers by examining histograms, this method will use the supervised classification function available in the ERDAS to classify the expected land uses/land covers. An example of using the spectral analysis for the *fc* dataset in Sabah and Sarawak in 2003 is presented (Figure 55).

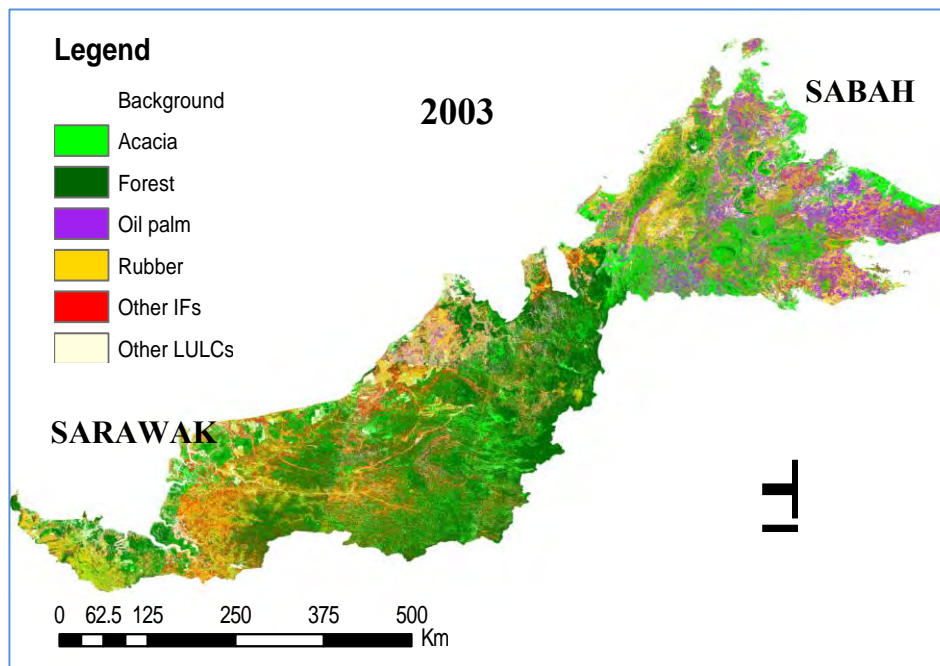
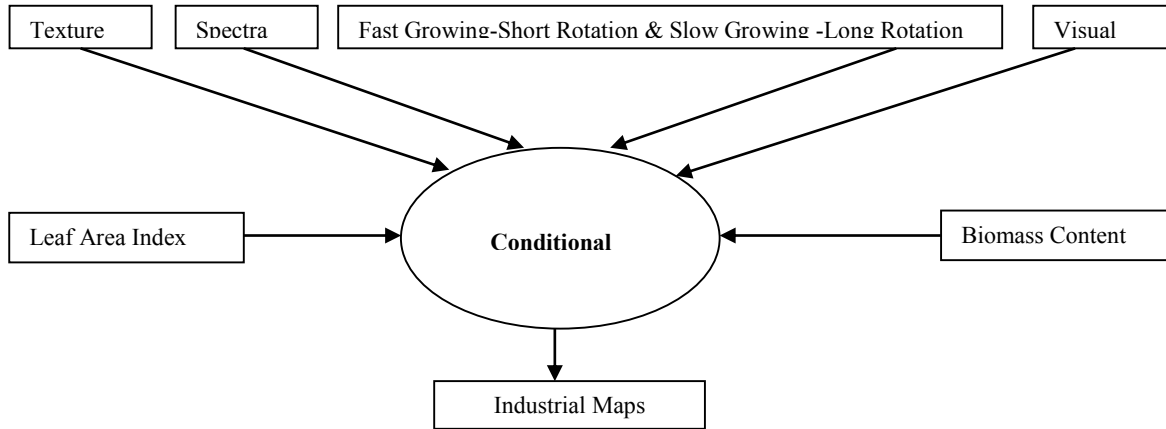

Figure 55. The spectral analysis-based land use/land cover map based the *fc* dataset in Sabah and Sarawak, 2003.

After obtaining the *fc*, LAI, biomass content, texture, and spectral datasets, *visual interpretation*, and other LULCC and ancillary data will be used to calibrate the final results for detecting industrial forests. The results of using visual interpretation and other ancillary data are described and acquired from the VIs-based IF detection method above.

For *IF maps*, an algorithm based on rules for the rotation, growing rate, leaf area index, biomass content, textural, spectral, and visual analyses mentioned above will be developed. The algorithm is simply illustrated (Figure 56). An example of IF detection and map in Sabah and Sarawak in 2009 is also presented (Figure 57).



$$\begin{aligned}
 f(\mathbf{IFs}) = \sum & ([\text{Texture}(\mathbf{IFs}) \cap \text{Spectra}(\mathbf{IFs}) \cap \text{FGSR-SGLR}(\mathbf{IFs}) \cap \text{Visual}(\mathbf{IFs}) \cap \text{Biomass}(\mathbf{IFs}) \cap \text{LAI}(\mathbf{IFs})] \\
 & + [\text{Texture}(\mathbf{IFs}) \cap \text{Spectra}(\mathbf{IFs}) \cap \text{FGSR-SGLR}(\mathbf{IFs}) \cap \text{Biomass}(\mathbf{IFs}) \cap \text{LAI}(\mathbf{IFs})] \\
 & + [\text{FGSR-SGLR}(\mathbf{IFs}) \cap (\text{Texture}(\mathbf{IFs}) \text{ OR/AND Spectra}(\mathbf{IFs}) \text{ OR/AND Biomass}(\mathbf{IFs}) \\
 & \text{OR/AND LAI}(\mathbf{IFs}))] \\
 & + [\text{Visual}(\mathbf{IFs}) \cap (\text{Texture}(\mathbf{IFs}) \text{ OR/AND Spectra}(\mathbf{IFs}) \text{ OR/AND FGSR-SGLR}(\mathbf{IFs}) \\
 & \text{OR/AND Biomass}(\mathbf{IFs}) \text{ OR/AND LAI}(\mathbf{IFs}))]).
 \end{aligned}$$

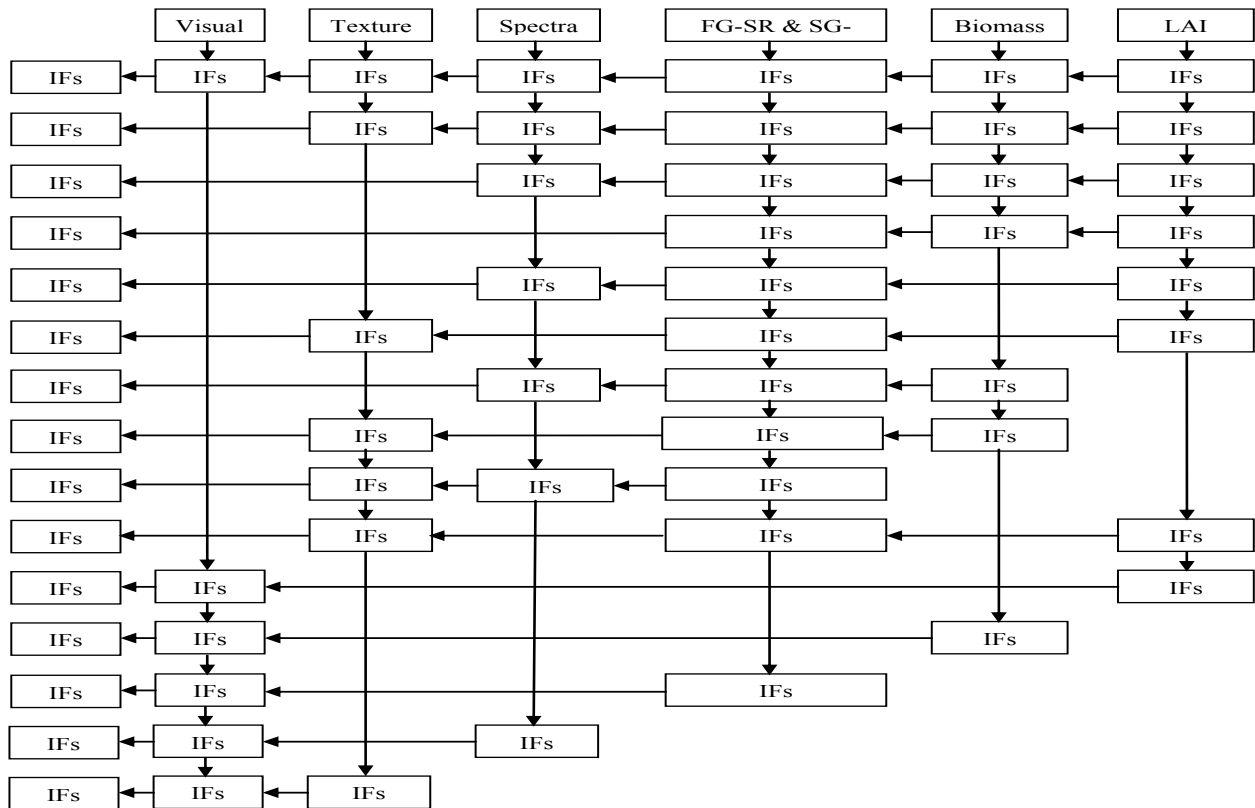

Figure 56. The combinations of different datasets to detect and map IFs in Sabah & Sarawak.

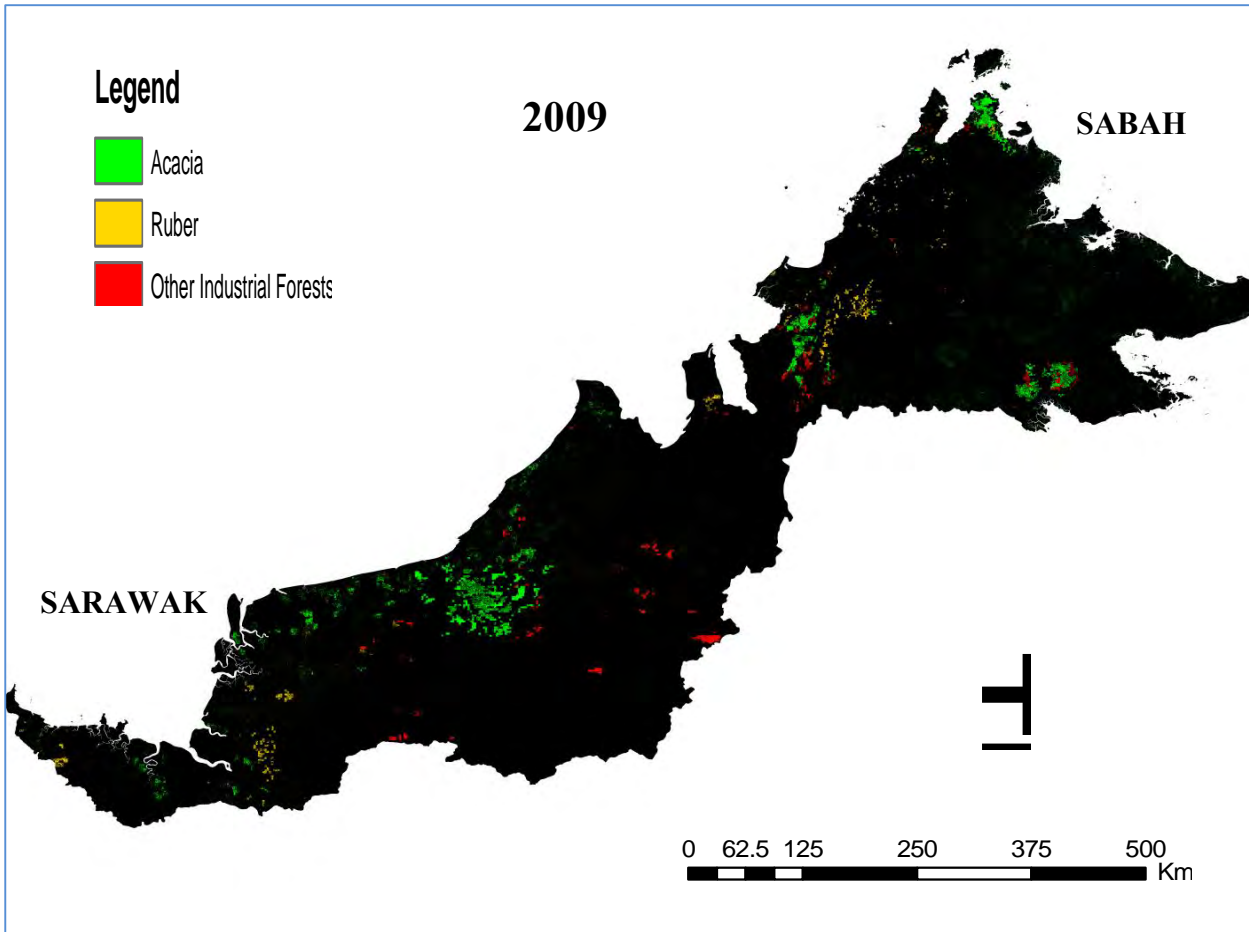

Figure 57. The *fc* dataset-based IF detection and map for Sabah and Sarawak in 2009.

The above are presented our IF detection methods development results for Landsat data. The next works for this project will be validation for these methods and methods development for high resolution imagery dataset.

IV. REFERENCE

- Barr, C. (2007). Intensively managed forest plantations in Indonesia: Overview of recent trends and current plans. In *Meeting of the Forest Dialogue*, Center for International Forestry Research. Pekanbaru, Indonesia.
- Barney, K. (2005a). At the supply edge: Thailand's forest policies, plantation sector, and commodity links with China. In *China and forest trade in the Asia-Pacific Region: Implications for Forests and Livelihoods*. Forest Trends. Washington DC, USA.
- Barney, K. (2005b). Central plans and global exports: Tracking Viet Nam's forestry commodity chains and export links to China. In *Asia Pro Eco Programme*. Forest Trends. Washington DC. USA.
- Blaser, J., Sarre, A., Poore, D., & Johnson. S. (2011). Status of tropical forest management 2011. In *ITTO Technical Series No 38*. International Tropical Timber Organization, Yokohama, Japan.
- Broge, N. H., & Leblanc, E. (2000). Comparing prediction power and stability of broadband and hyperspectral vegetation indices for estimation of green leaf area index and canopy chlorophyll density. *Remote Sensing of Environment*, 76, 156-172.
- FAO. (2000). State of the World's forest 2000. United Nations Food and Agricultural Organization. Rome, Italy.
- FAO. (2005). State of the World's forest 2005. United Nations Food and Agricultural Organization, Rome, Italy.
- FAO. (2009). State of the World's forest 2009. United Nations Food and Agricultural Organization, Rome, Italy.
- FAO. (2010). Global Forest Resources Assessment. *Country Report: Indonesia*. Food and Agriculture Organization (FAO). Rome, Italy.
- Haboudane, D., Miller, J. R., Pattey, E., Zarco-Tejada, P. J., & Strachan, J. B. (2004). Hyperspectral vegetation indices and novel algorithms for predicting green LAI of crop canopies: Modeling and validation in the context of precision agriculture. *Remote Sensing of Environment*, 90, 337-352.
- ICFRE. (2010). Forest sector report of India 2010. In *New Forest*, India Council of Forestry Research and Education. Dehradun, Uttarakhand, India.
- ICFRE. (2011). Forestry Statistics India 2011. In *New Forest*, India Council of Forestry Research and Education. Dehradun, Uttarakhand, India.

- Indonesia Forestry Outlook Study. (2009).** Asia-Pacific forestry sector outlook study II. In *FAO Working Paper No. APFSOS II/WP/2009/13*, Center for Forestry Planning and Statistics, Indonesian Ministry of Forestry. Jakarta, Indonesia.
- ITTO. (2009).** Encouraging industrial forest plantations in the tropics. In *ITTO technical series No.33 report of a global study*. International Tropical Timber Organization, Yokohama, Japan.
- Malaysian Timber Council. (2009).** Malaysia: forestry & environment (facts and figures). Kuala Lumpur, Malaysia.
- Malaysia Forestry Outlook Study. (2009).** Malaysia forestry outlook study. In *Asia-Pacific forestry sector outlook study II, FAO Working Paper Series No. APFSOS II/WP/2009/22*. Regional office for Asia and the Pacific. Bangkok, Thailand.
- Malik, A. R. H. A., Hamzah, K. A., & Joseph. K. T. (2013).** Land use change in Malaysia. *Reports from the Technical Panels of the 2nd Greenhouse Gas*. Working Group of the Roundtable on Sustainable Palm Oil (RSPO). Malaysia.
- Ministry of Agriculture and Rural Development/MARD. (2012).** Forestry statistics of Viet Nam. *Decision 1739*. Hanoi, Viet Nam.
- Ministry of Agriculture and Rural Development MARD. (2010).** Vietnam forestry development strategy 2006-2020. *Progress report 2006-2010*. Forest Sector Monitoring Information System, Forest Sector Support Partnership. Hanoi, Viet Nam.
- Ministry of Environment and Forests. (2007).** Asian Pacific Forestry Sector Outlook Study-II. In *FAO Working Paper No. APFSOS II/WP/2009/13*. The Government of India.
- Luan, K.N. (2013).** Natural rubber industry report. In *the 2013 FPT Securities report*. Ho Chi Minh City, Viet Nam.
- Oberhauser, U. (1997).** Secondary forest regeneration beneath pine (*Pinus kesiya*) plantations in the northern Thai highlands: a chronosequence study. *Forestry Ecology and Management*, 99, 171-183.
- Thailand Rubber Statistics. (2011).** Retrieved at http://www.rubberthai.com/statistic/eng/eng_stat.htm
- Jegatheswaran, R., Ramasamy, G., & Ioras, F. (2012).** Production potential of rubberwood in Malaysia: Its economic challenges. *NOTULAE BOTANICAE HORTI AGROBOTANICI CLUJ-NAPOCA*, 40, 317-322.
- Jaakko Pöyry Development Oy. (2001).** The development potential of Vietnam's wood growing sector: *Final report* (prepared for the World Bank).

- Viet Nam Forestry Outlook Study. (2009). Viet Nam Forestry Outlook Study. In *Asia-Pacific Forestry Sector Outlook Study II, Working Paper Series No. APFSOS II/WP/2009/22*. FAO Regional Office for Asia and the Pacific. Bangkok, Thailand.
- Huete, A. R. (1988). A soil-adjusted vegetation index (SAVI). *Remote Sensing of Environment*, 25, 295-309.
- Huete, A., Didan, K., Miura, T., Rodriguez, E. P., Gao, X., & Ferreira, L.G. (2002). Overview of the radiometric and biophysical performance of the MODIS vegetation indices. *Remote Sensing of Environment*, 83, 195-213.
- Kaufman, Y. J., & Tanre, D. (1992). Atmospherically resistant vegetation index (ARVI) for EOS-MODIS, in *Proc. IEEE Int. Geosci. and Remote Sensing Symp. 1992*, 261- 70. New York, USA.
- Matricardi, E. A. T., Skole, D. L., Pedlowski, M. A., Chomentowski, W., & Fernandes, L.C. (2010). Assessment of tropical forest degradation by selective logging and fire using landsat imagery. *Remote Sensing of Environment*, 114, 1117–1129.
- Qi, J., Chebbouni, A., Huete, A. E., Kerr, Y. H., & Sorooshian, S. (1994). A modified soil adjusted vegetation index. *Remote Sensing of Environment*, 48, 119-126.
- Somers, B., Asner, G. P., Tits, L., & Coppin, P. (2011). Endmember variability in spectral mixture analysis: A review. *Remote Sensing of Environment*, 115, 1603-1616.
- Wang, C., Qi, J., & Cochrane, M. (2005). Assessment of tropical forest degradation with canopy fractional cover from Landsat ETM+ and IKONOS Imagery. *Earth Interactions*, 9, 1–18.